

NIMROD DE ROSARIO

FUNDAMENTALS
OF THE
HYPERBOREAN
WISDOM

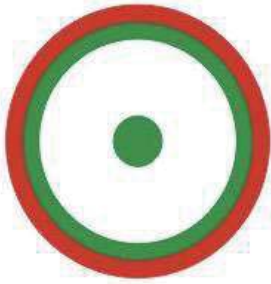

Images / Diagrams



SPIRIT-SPHERE



MATERIAL PLANE

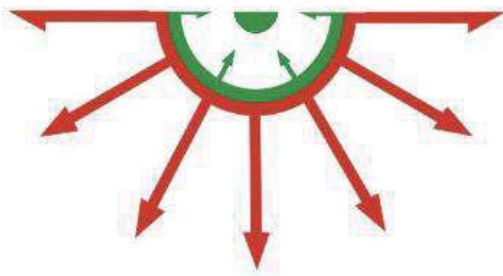

ORIENTATION OF THE SPIRIT (GREEN)

HOSTILITY OF THE SPIRIT-SPHERE (RED)



MATERIAL PLANE

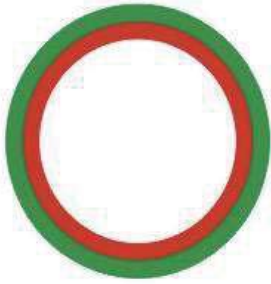

**SPIRIT CONFUSED
DISORIENTED OR
LOST (REVERTED)**

MATERIAL PLANE

NORMAL SPIRIT

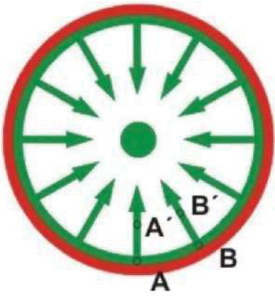

$$\overline{AB} > \overline{A'B'}$$

THE GAZES COME TOGETHER AS THEY APPROACH THE CENTER

REVERTED SPIRIT

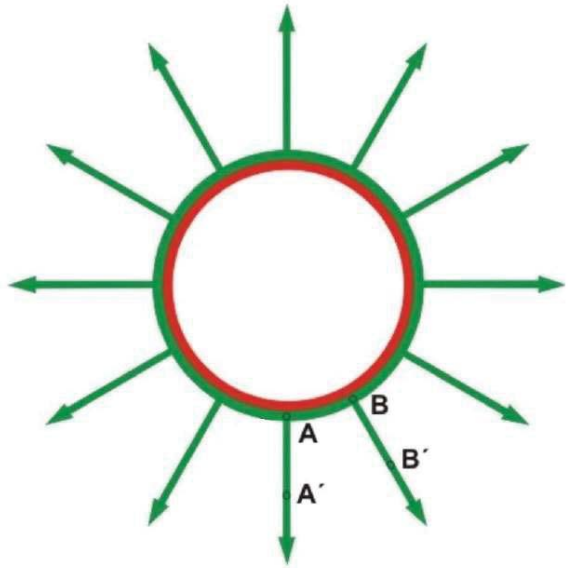

$$\overline{AB} < \overline{A'B'}$$

THE GAZES SEPARATE AS THEY MOVE AWAY FROM THE SPIRIT-SPHERE

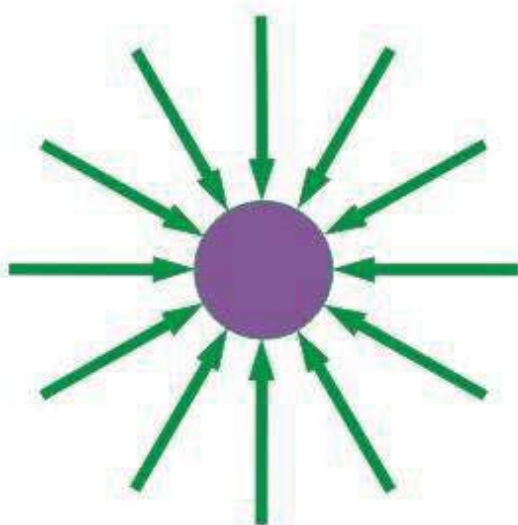

INFINITE POLE

REVERTED SPIRIT-SPHERE

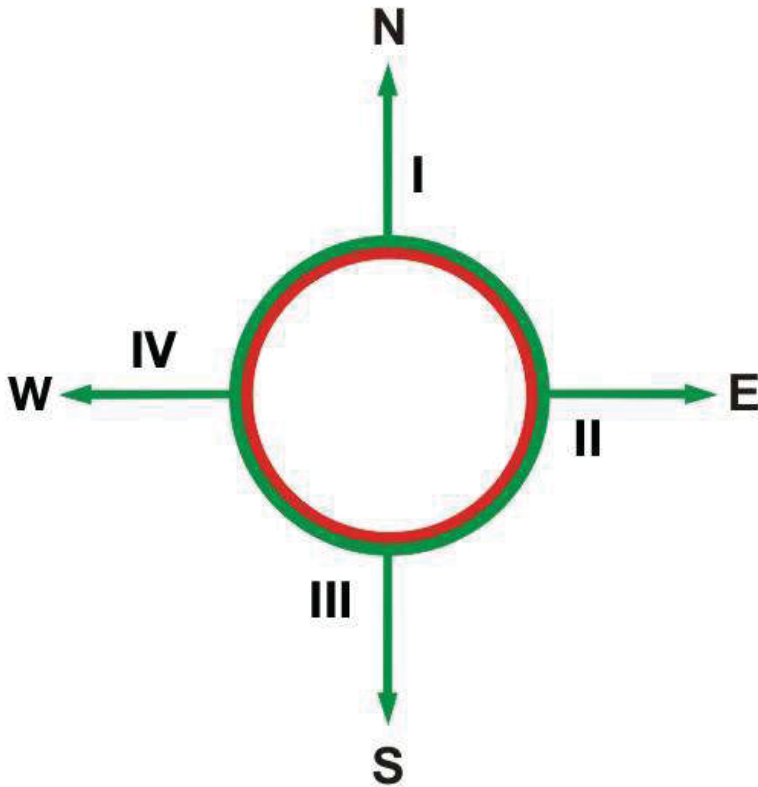

THE “GAZES” OR PROJECTIONS OF THE Gnostic POINTS I, II, III, & IV, ALTHOUGH THEY DEPART FROM DIFFERENT DIRECTIONS, ARE TO BE FOUND IN THE “INFINITE.”

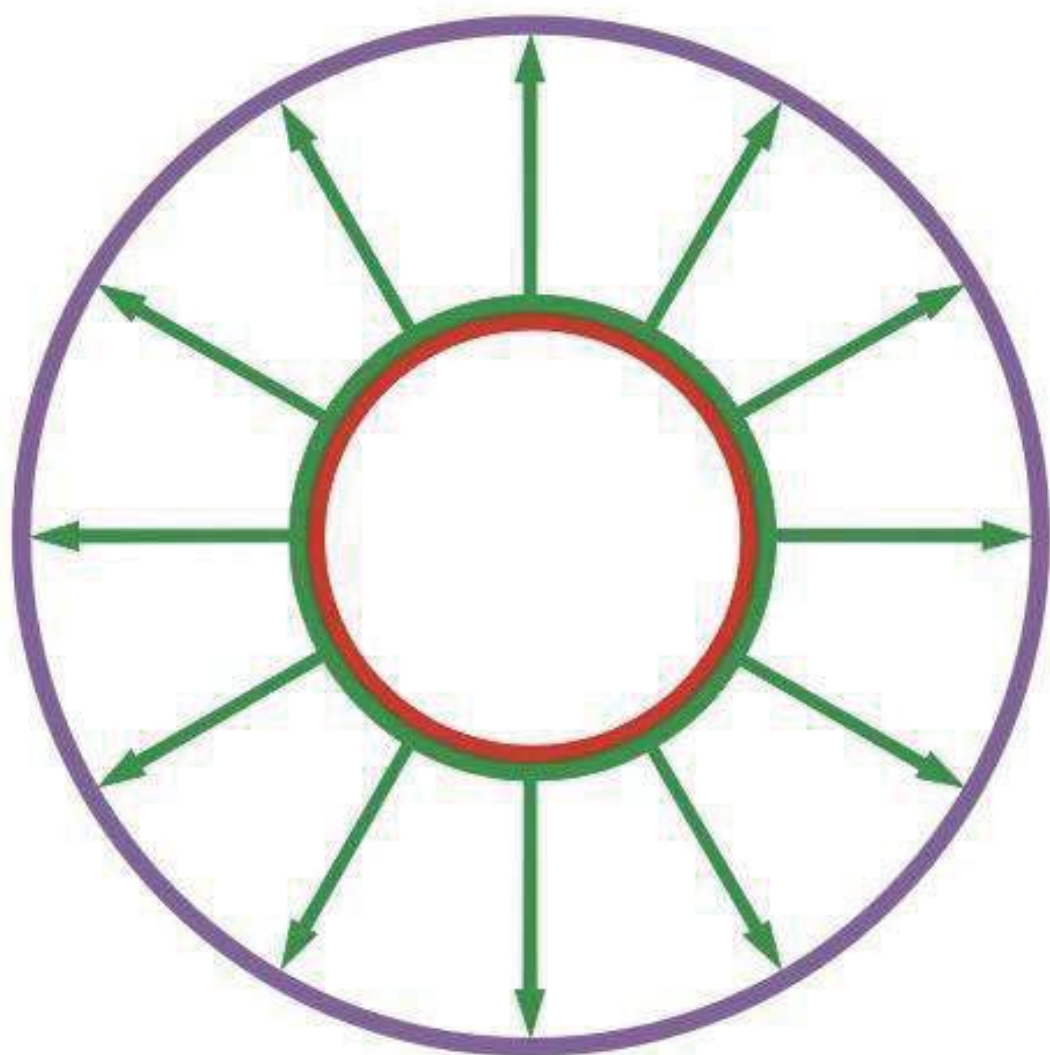

EXPANDED INFINITE POLE

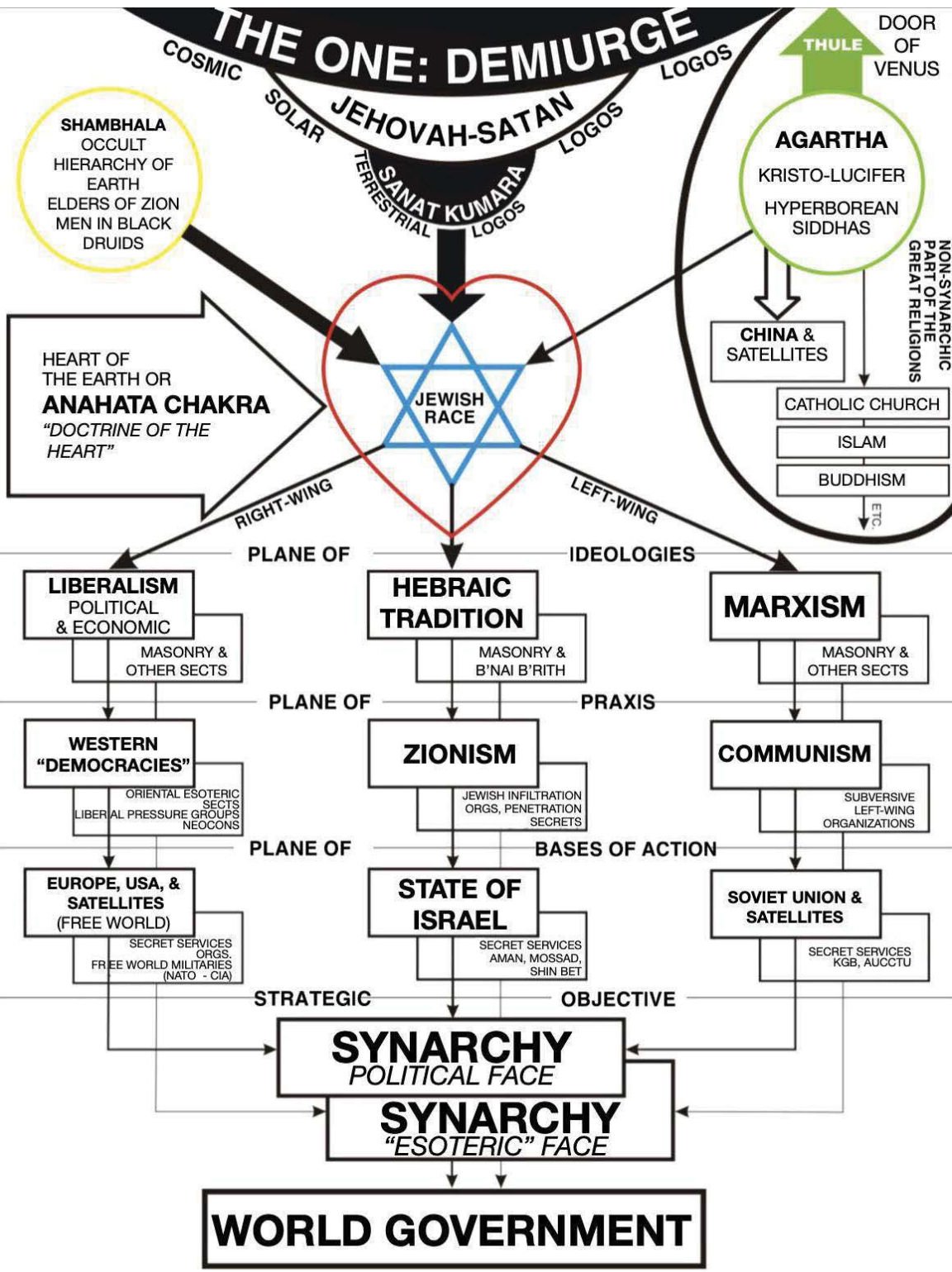

STRUCTURE OF THE UNIVERSE OR; "MACROCOSM"

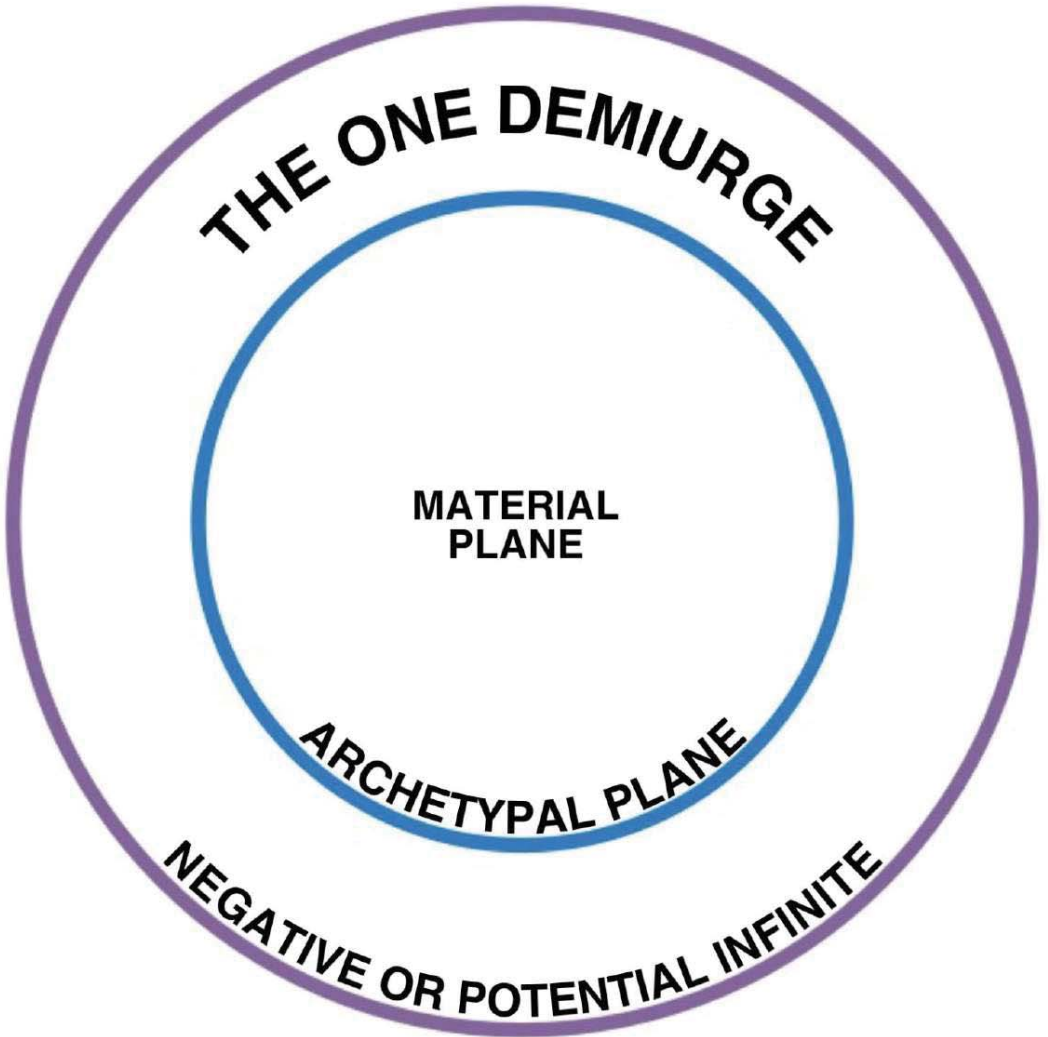

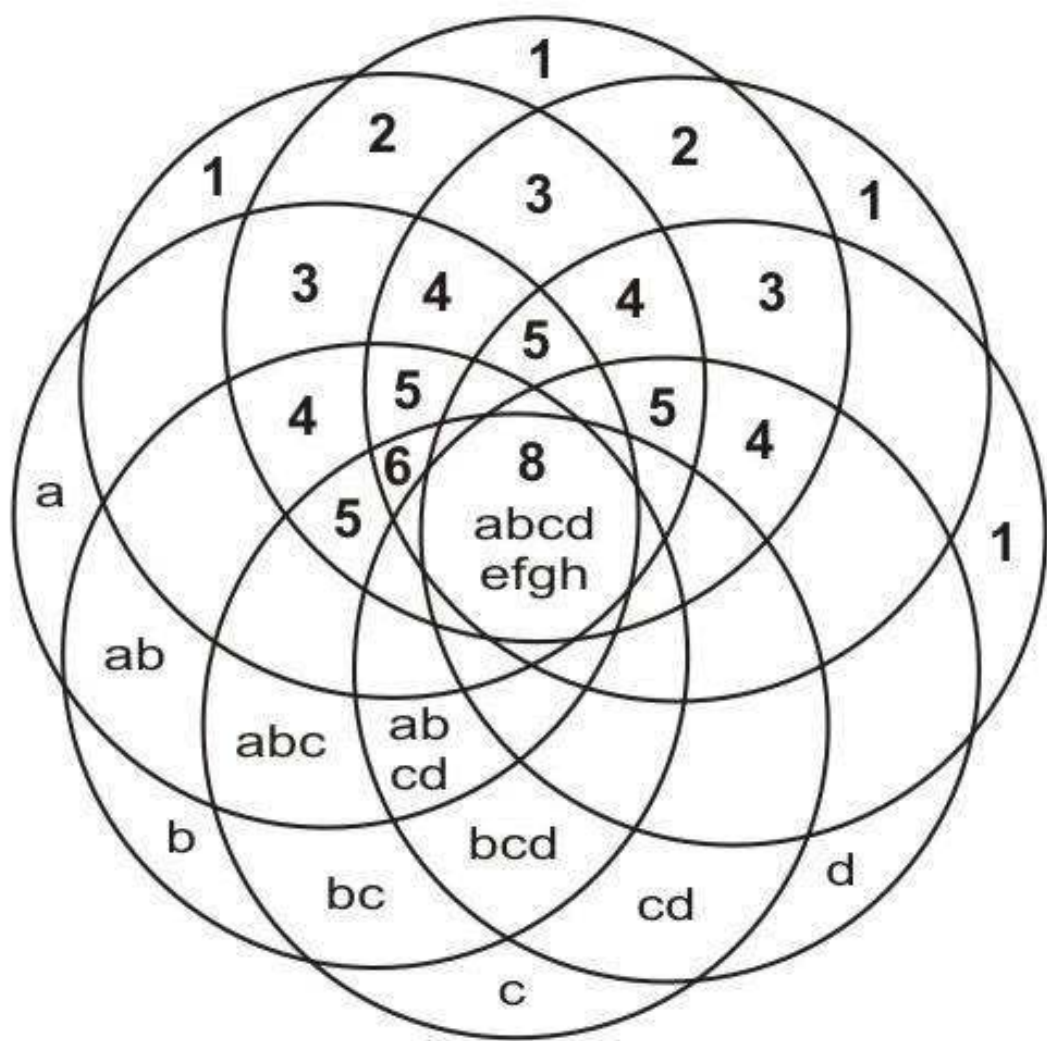

NUMERICAL & ATTRIBUTIVE SPACE
according to L. A. Lezama

PSYCHIC STRUCTURE OF THE PAŚU (PRIMITIVE)

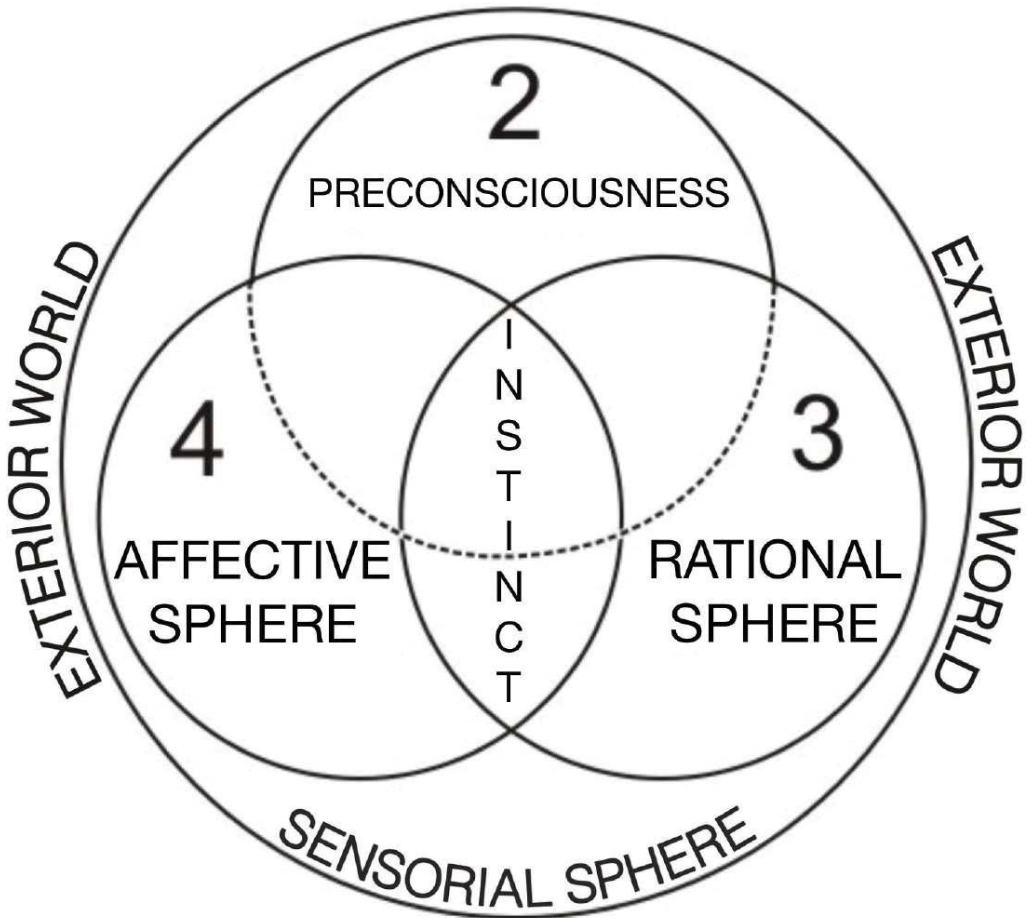

CUBIC STRUCTURE

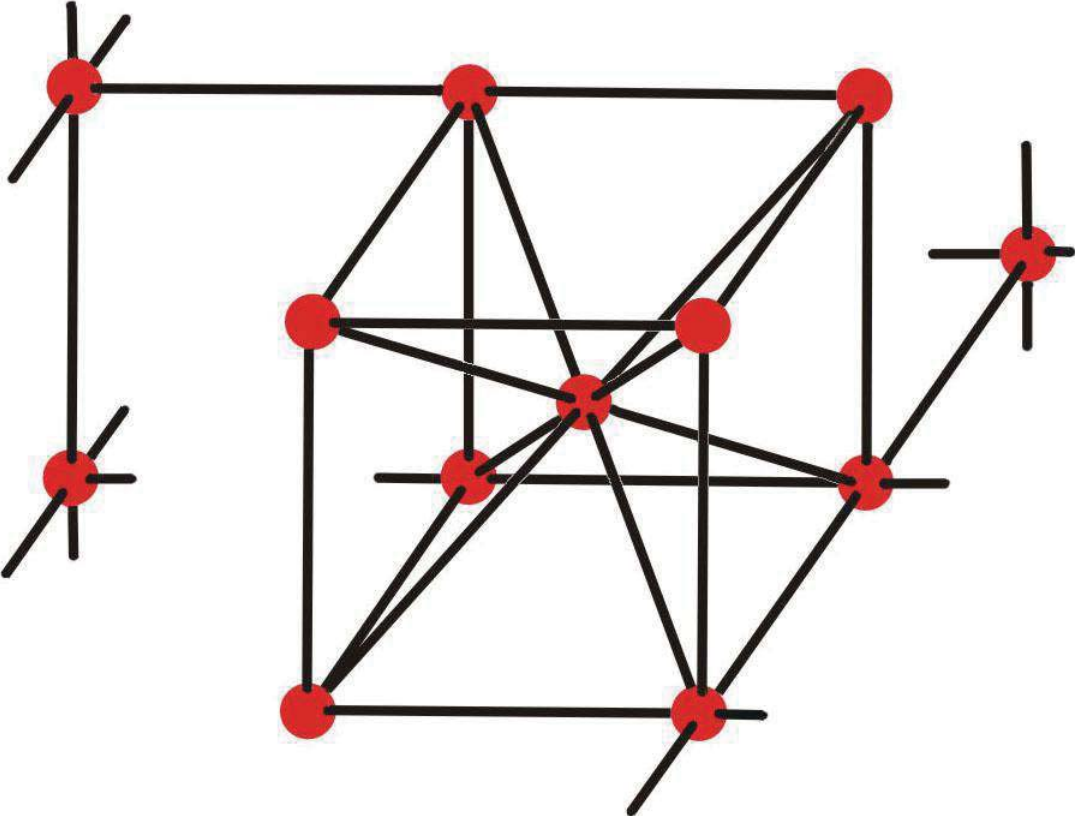

MINIMUM SYSTEM



ULTIMATE PSYCHIC STRUCTURE OF THE PASU

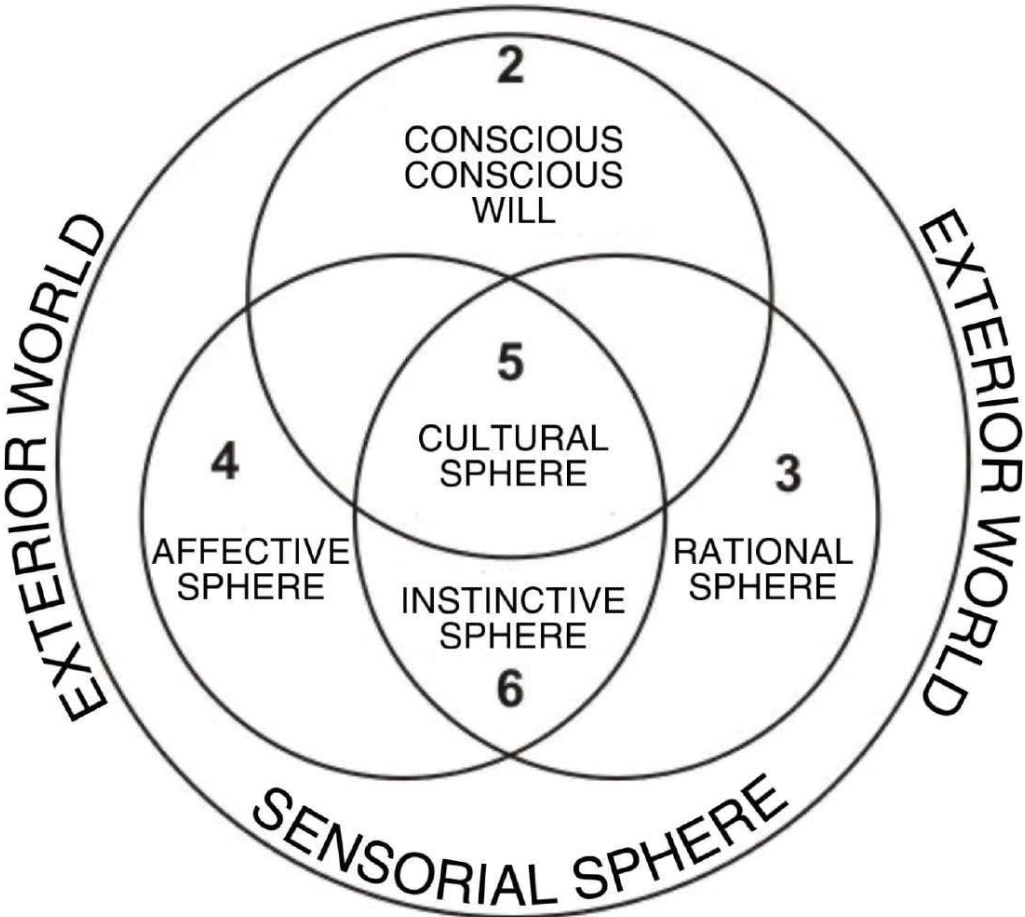

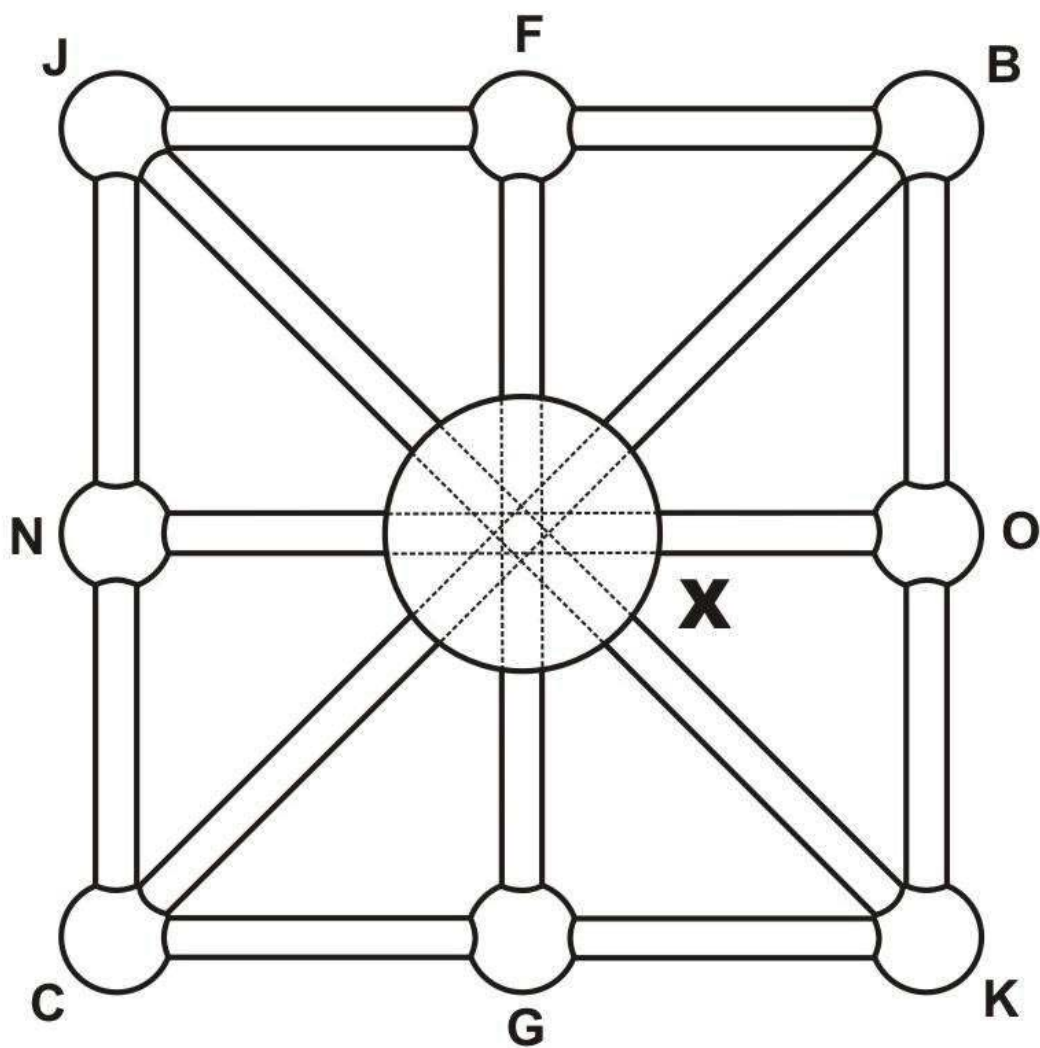

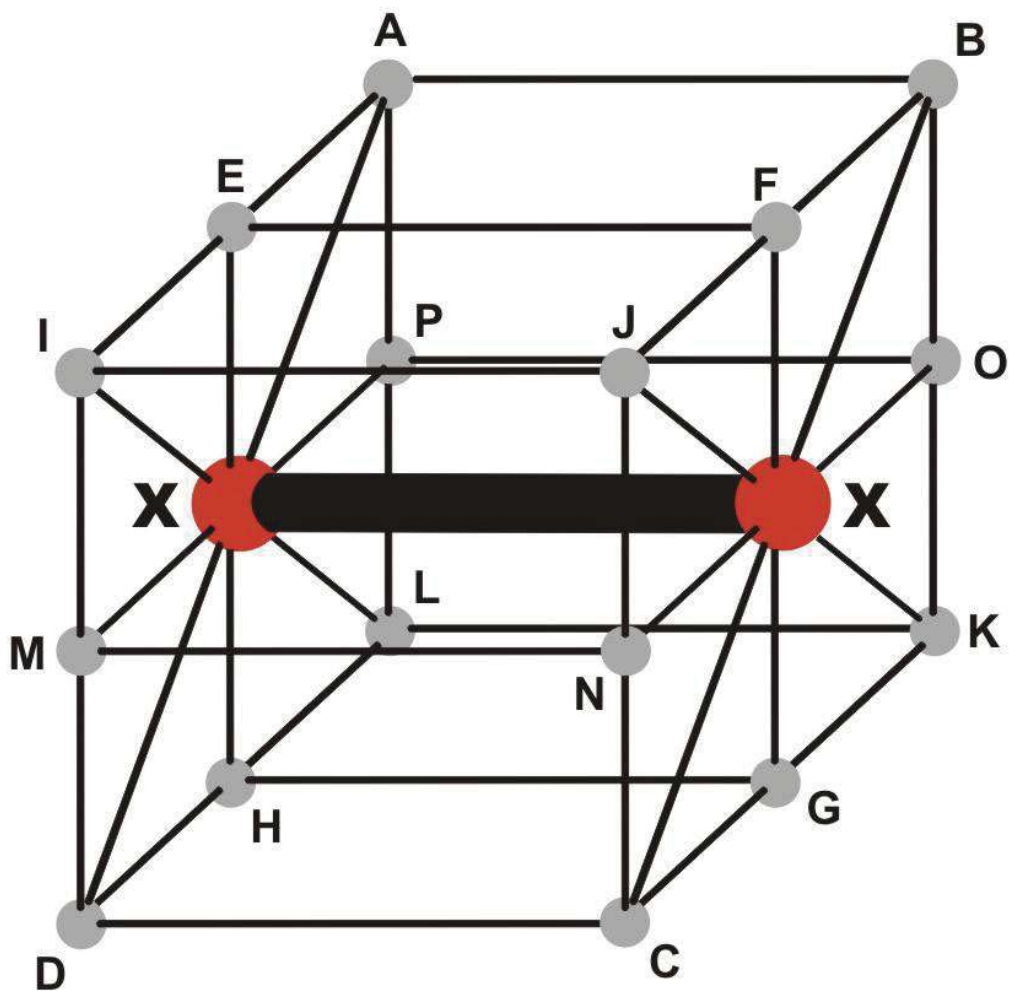

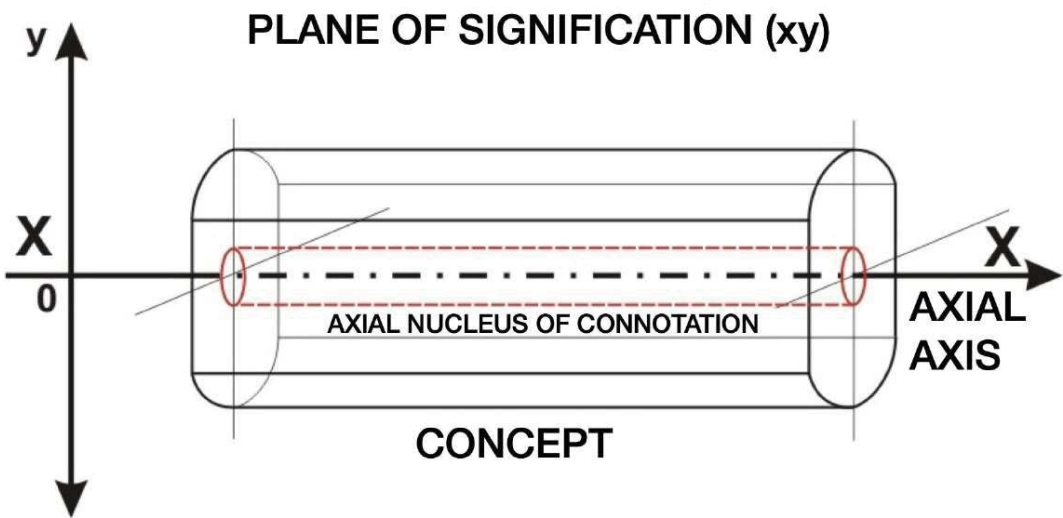

ANALOGY OF THE "CONCEPT" AS A SLICE OF THE RELATIONSHIP BOND

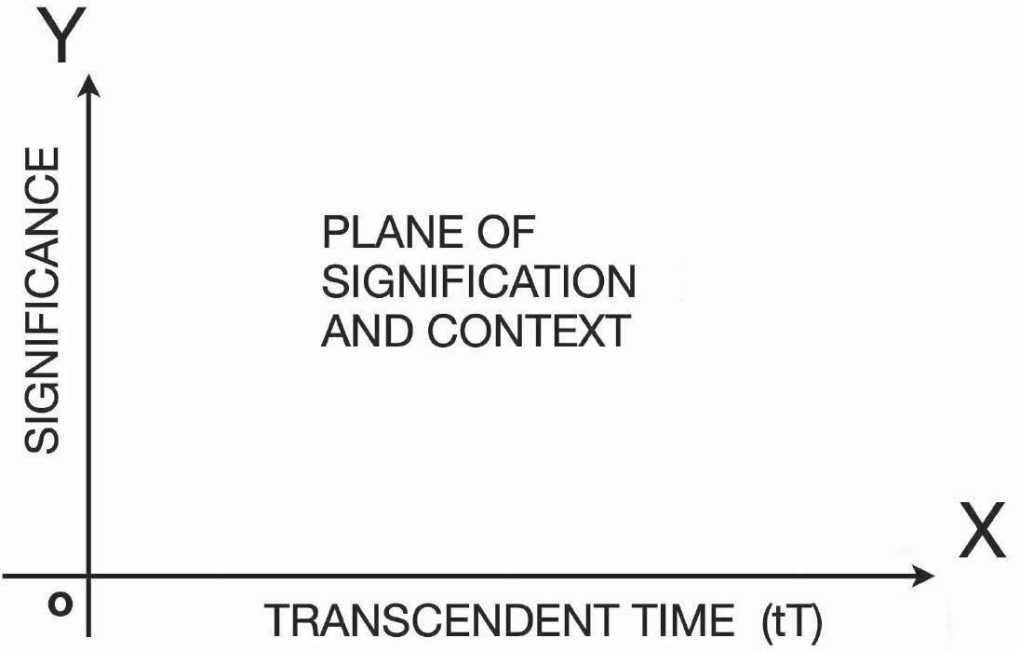

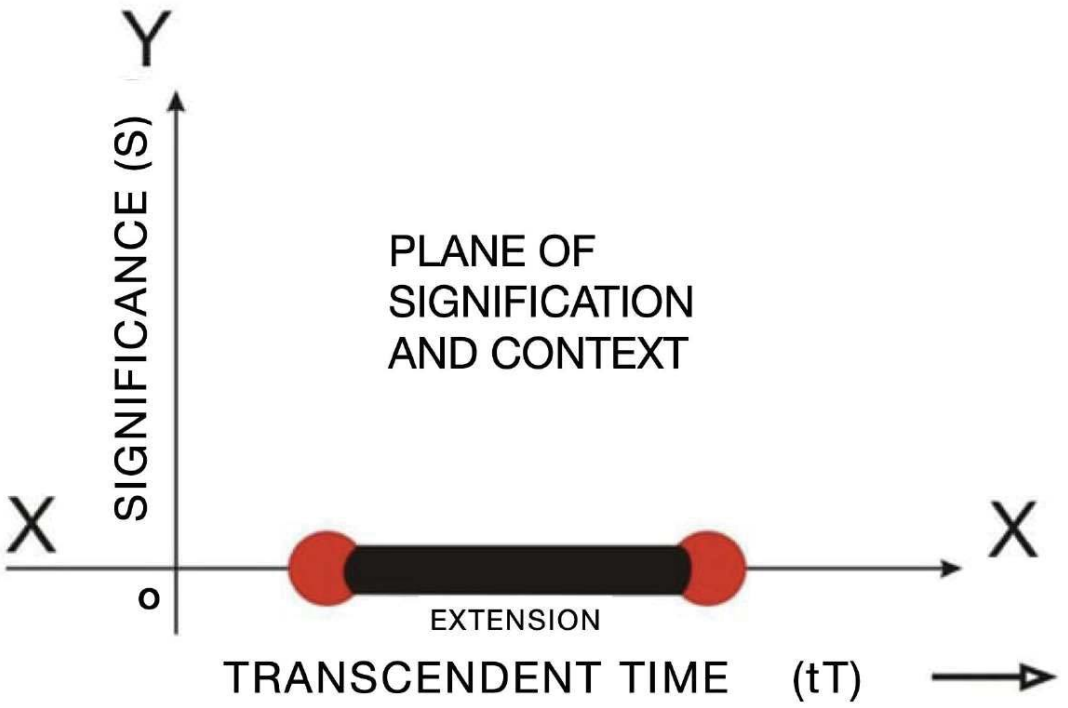

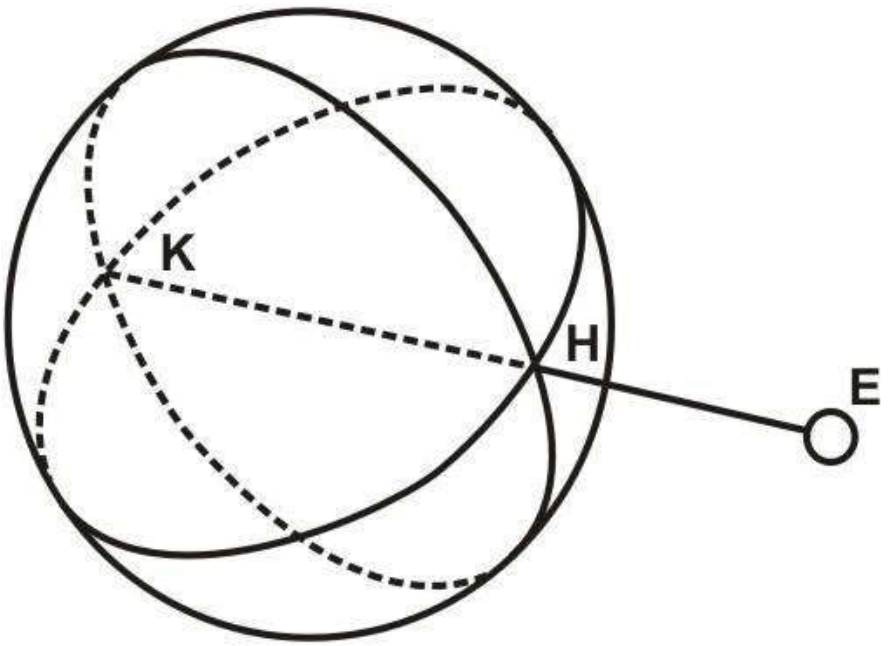

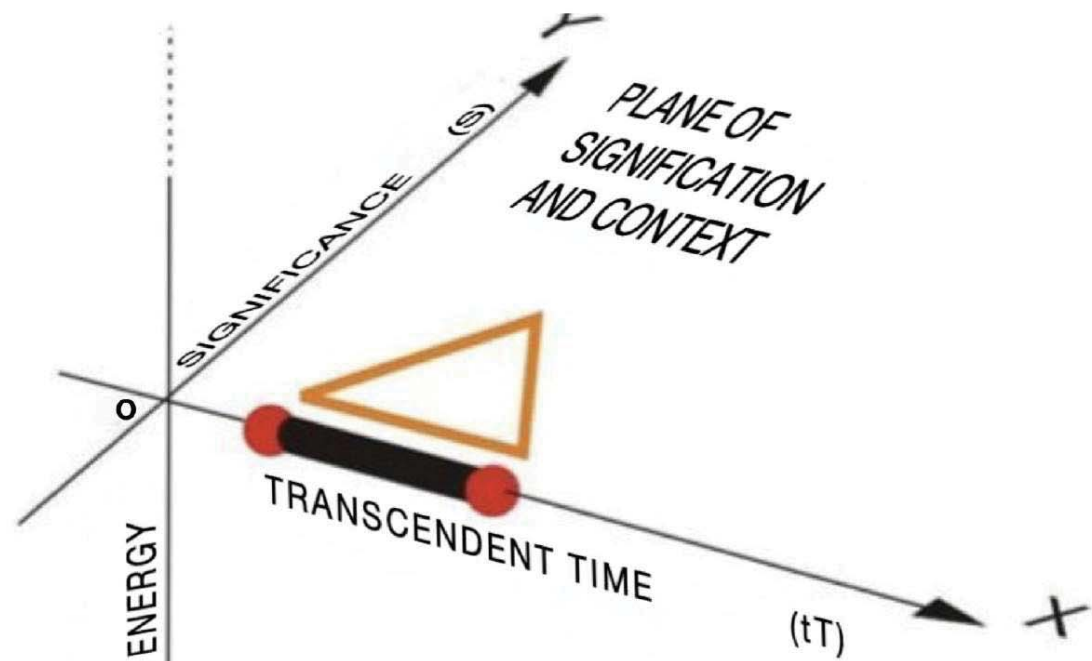

$(-pE)$

ENERGY

z

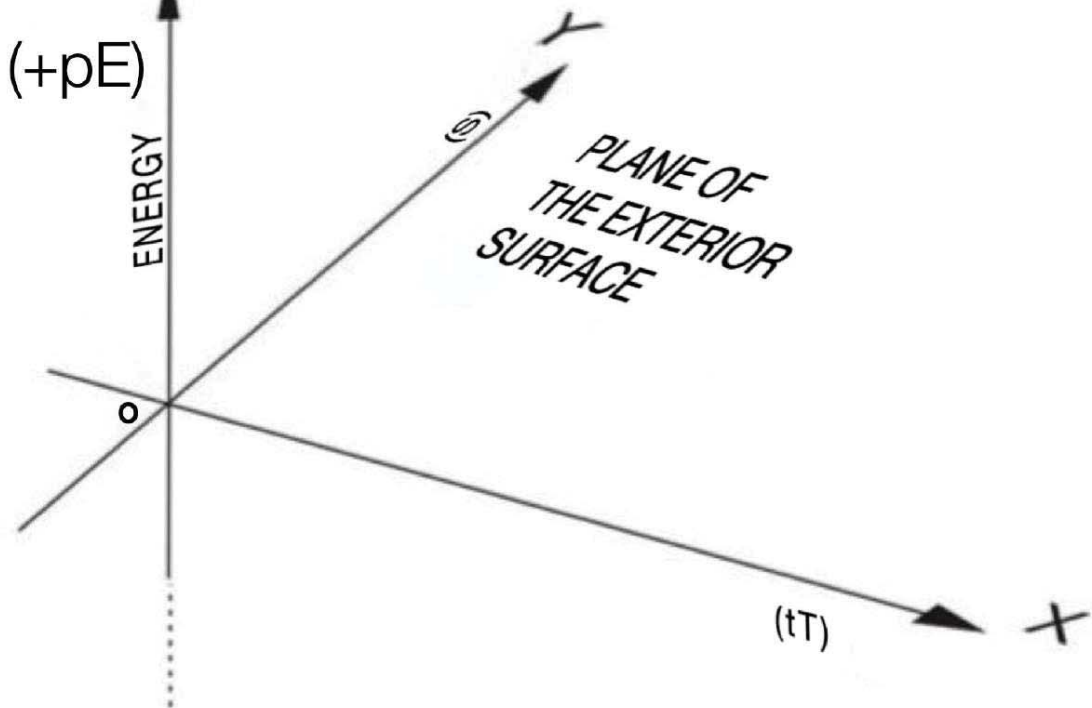

$(+pE)$

ENERGY

(tT)

PLANE OF THE EXTERIOR SURFACE

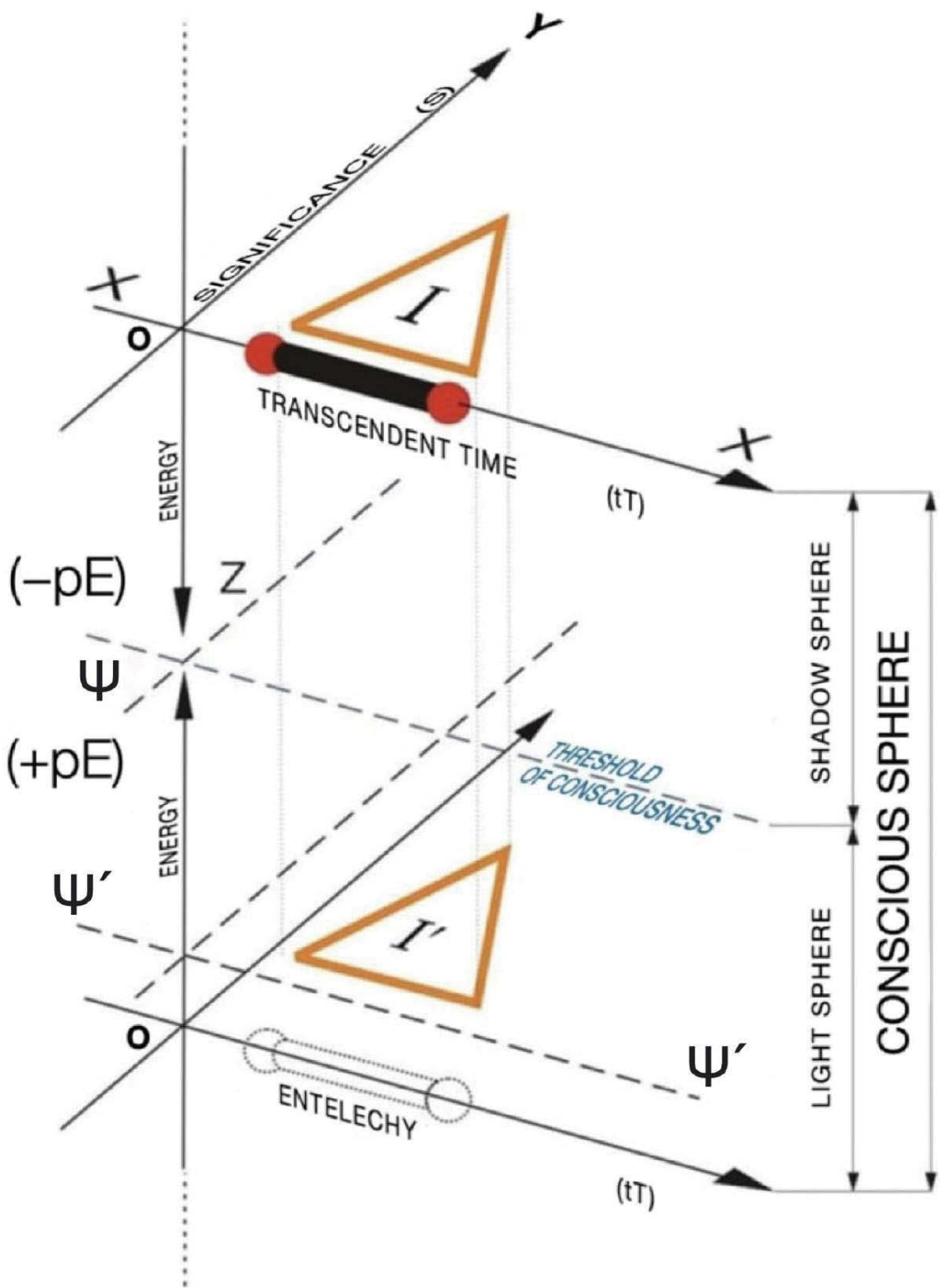

ENERGETIC ORIENTATION

OF THE AFFECTIVE FIELD AND EMOTIONAL FIELD

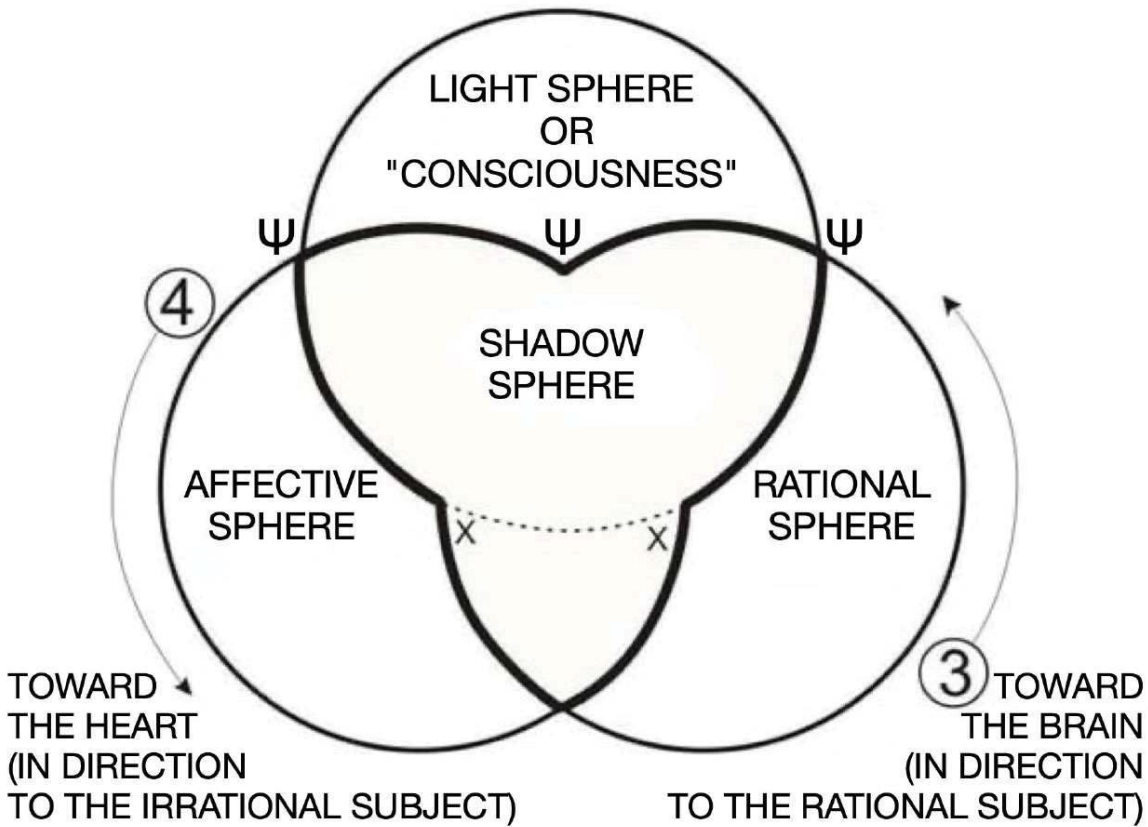

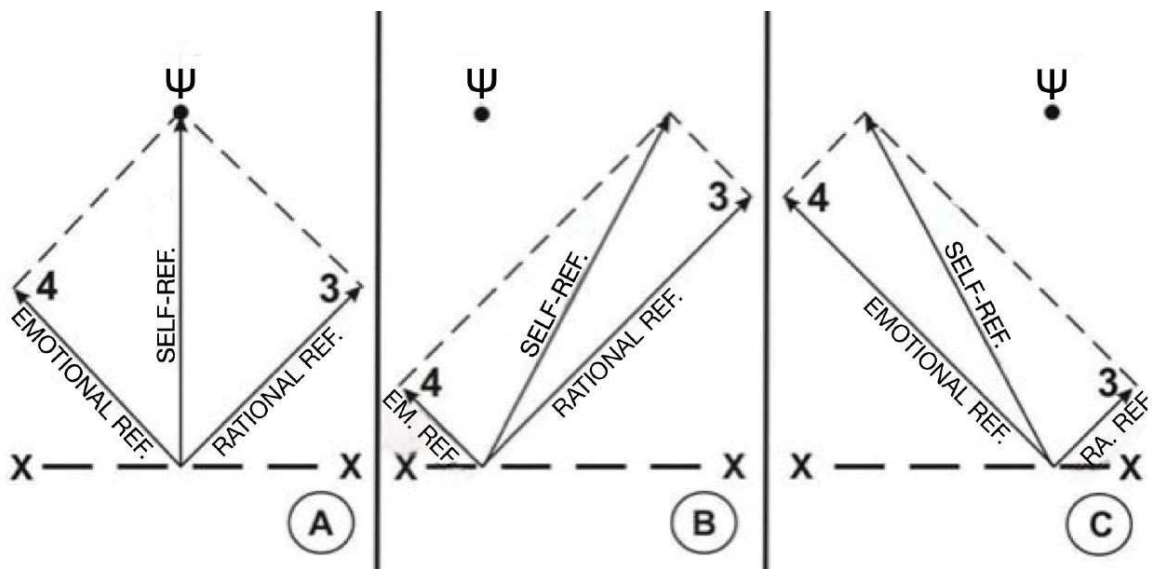

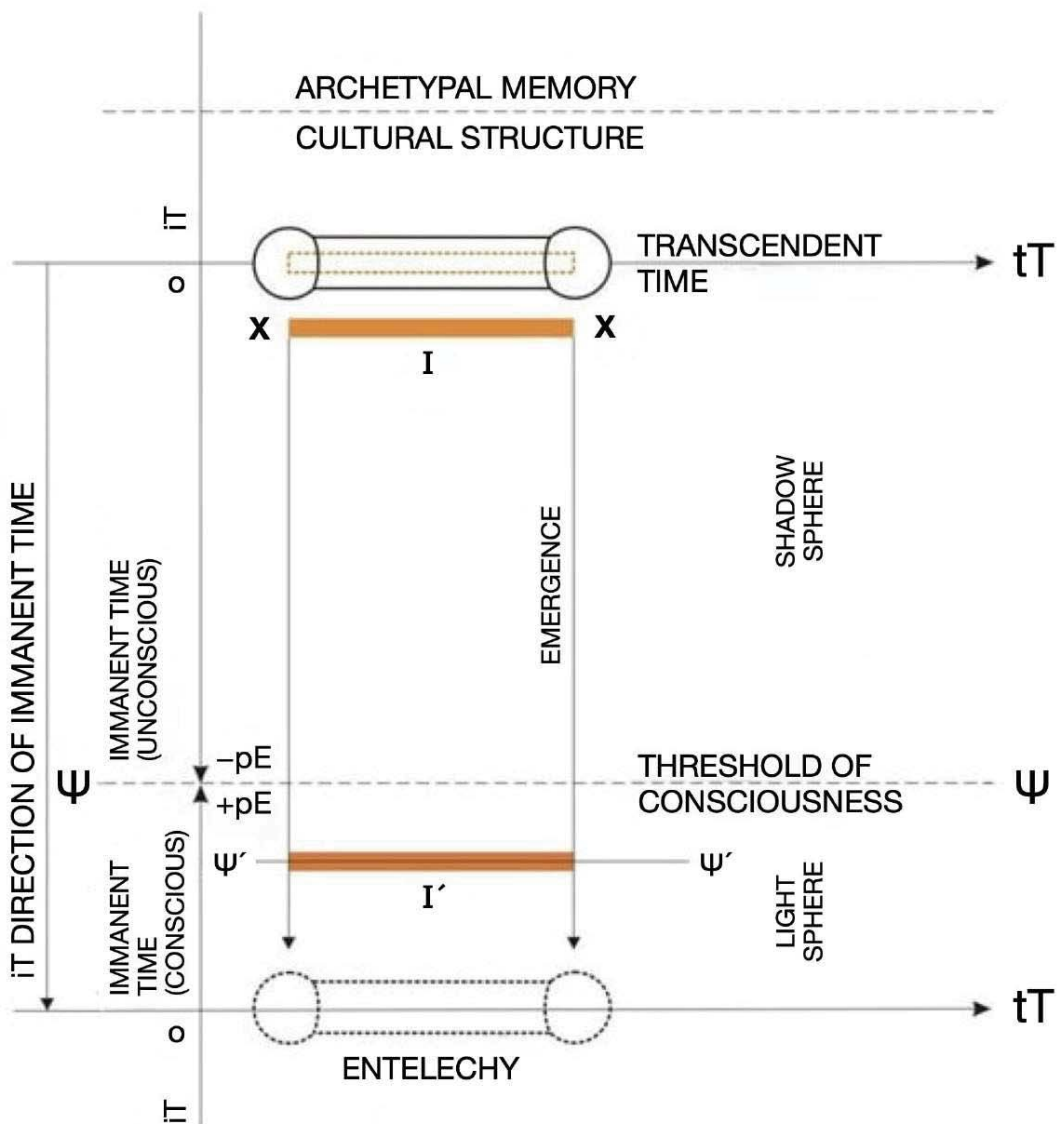

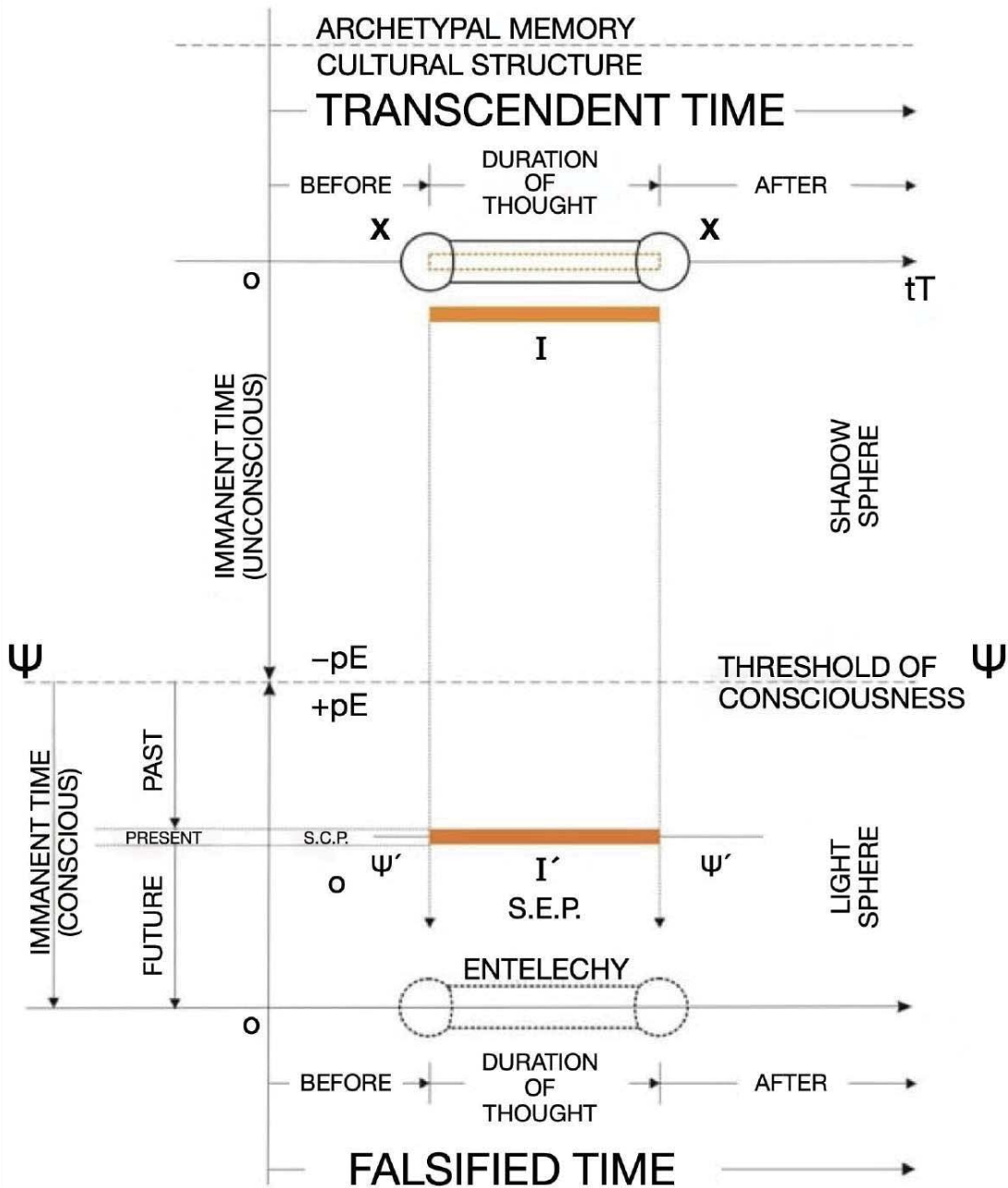

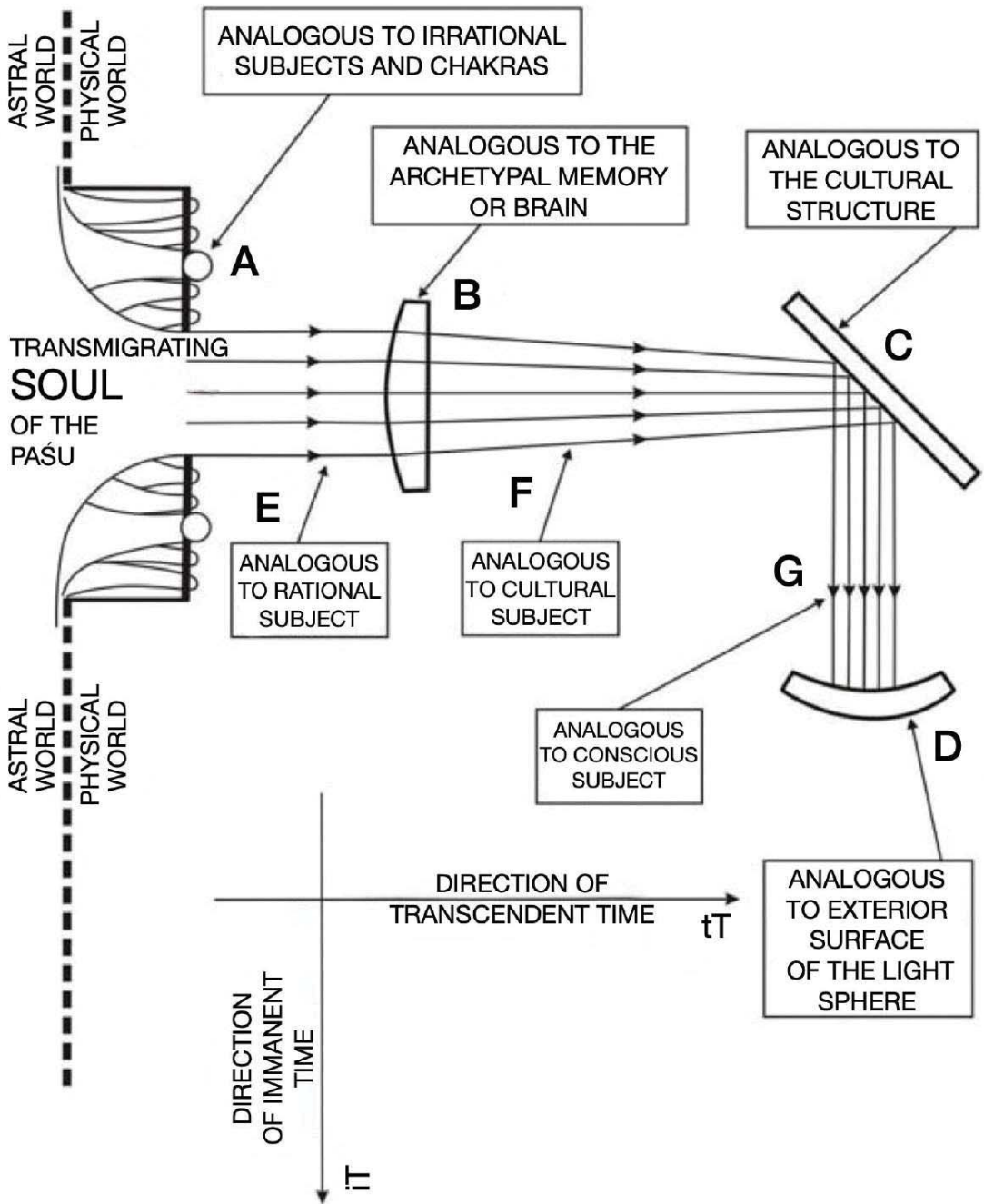

OPTICAL ANALOGY OF THE EVULSIVE ANIMIC SUBJECT OF THE PAŚU

THE MACROCOSM CONTAINS THE POTENTIAL MICROCOSM

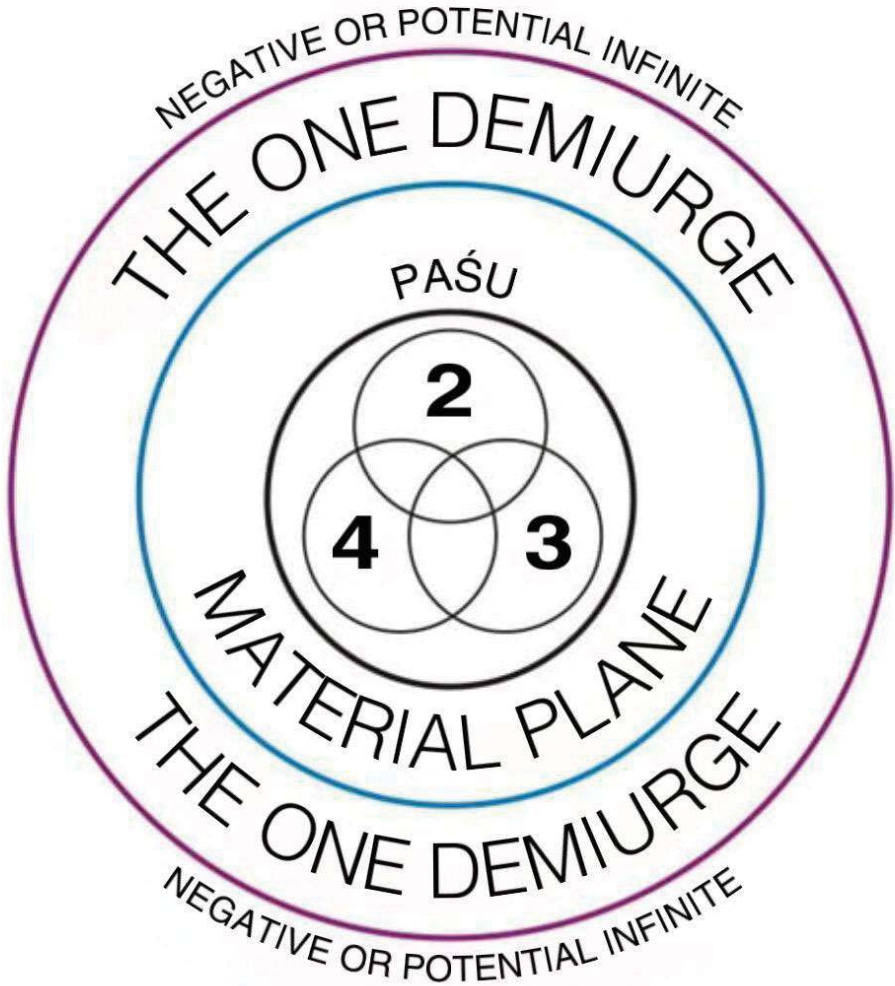

RELATIONSHIP BETWEEN THE REVERTED SPIRIT, THE MACROCOSM, AND THE MICROCOSM

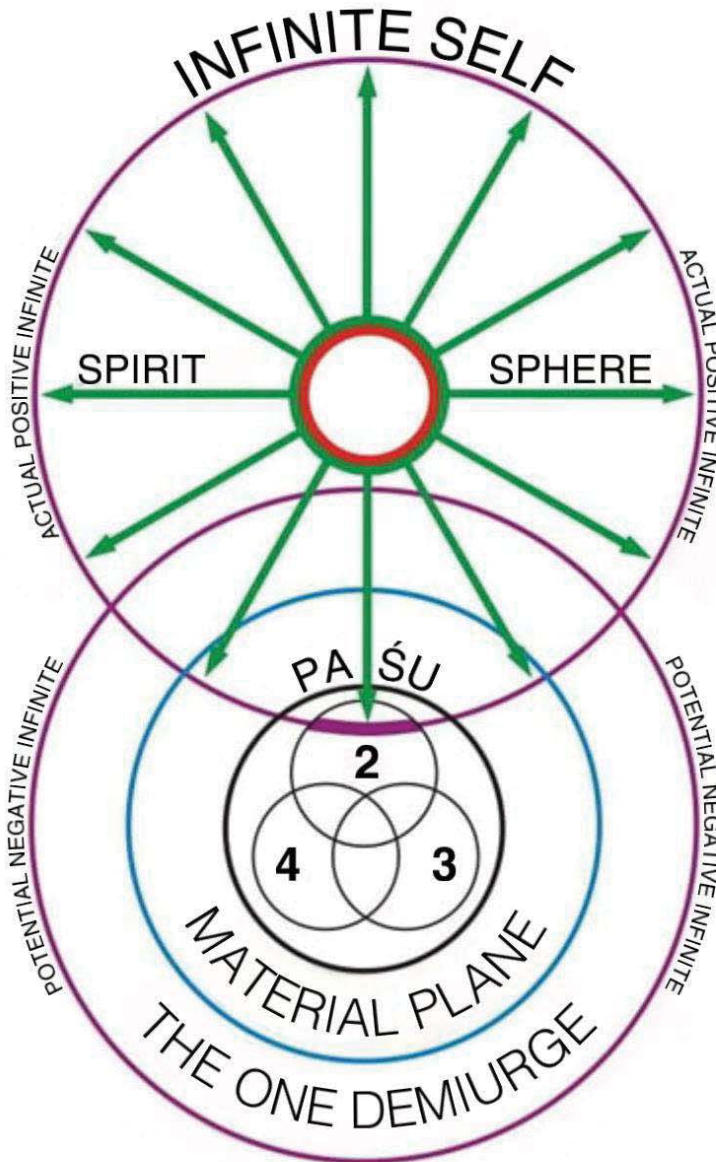

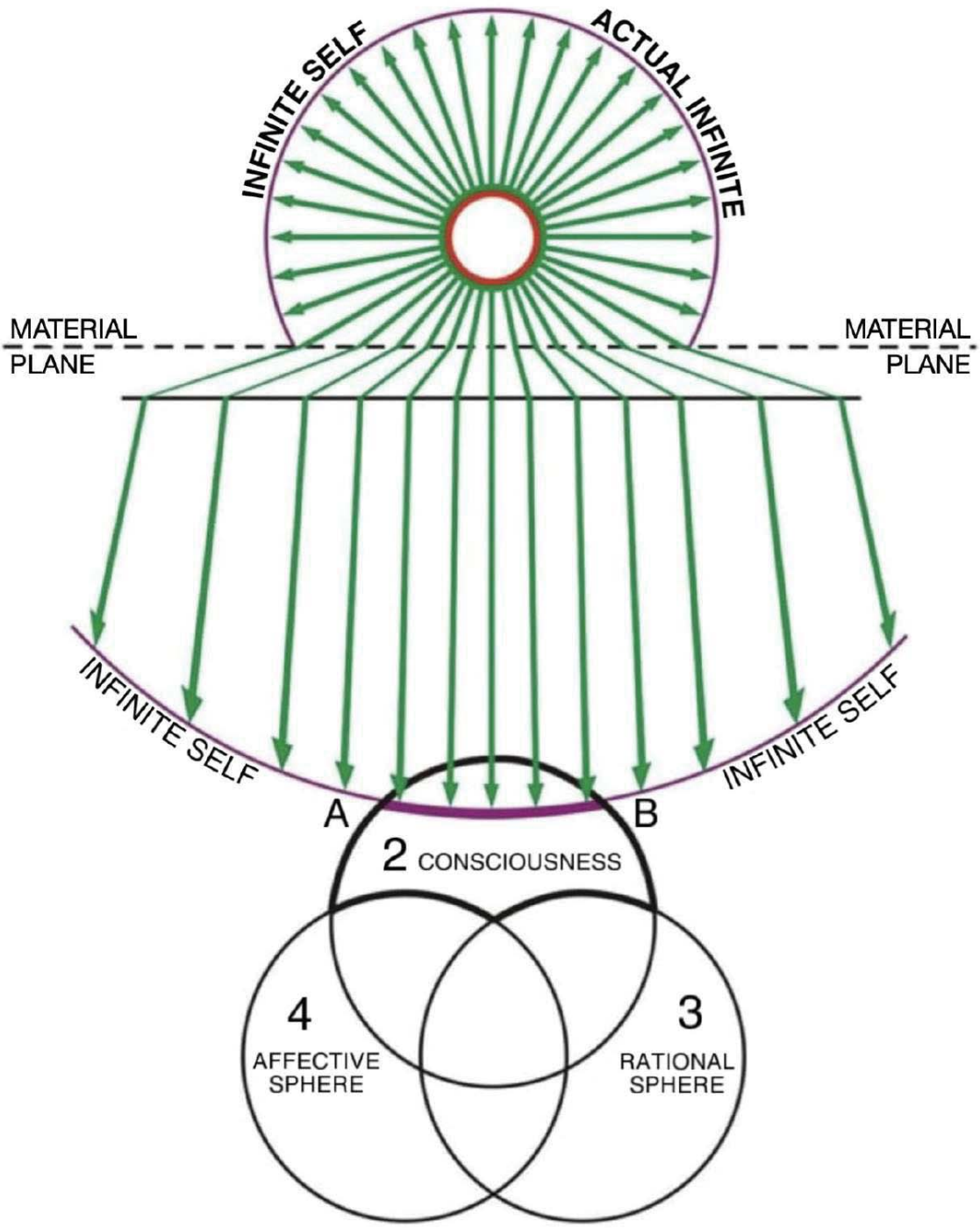

AB = SYMBOL OF THE ORIGIN

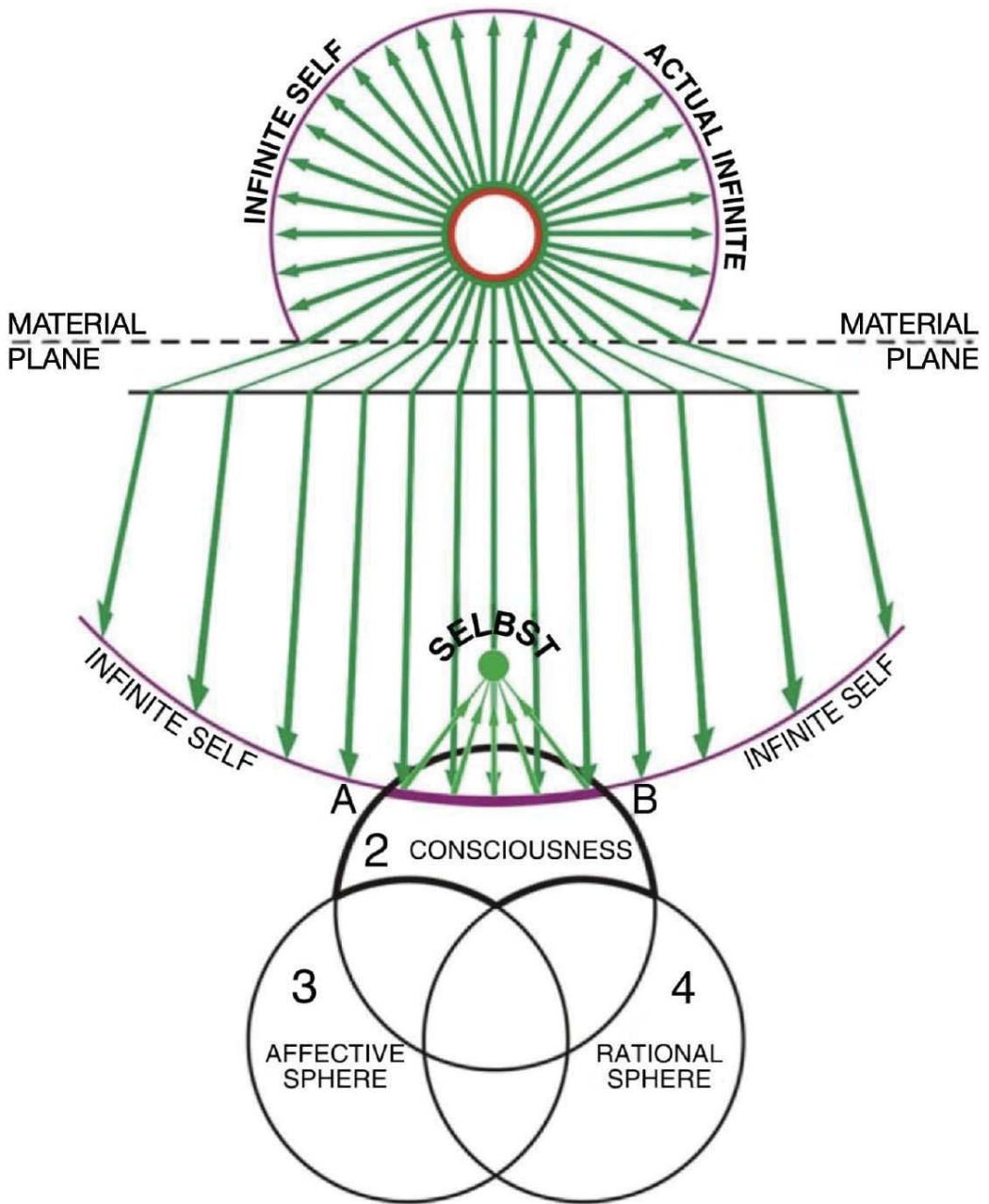

AB = SYMBOL OF THE ORIGIN

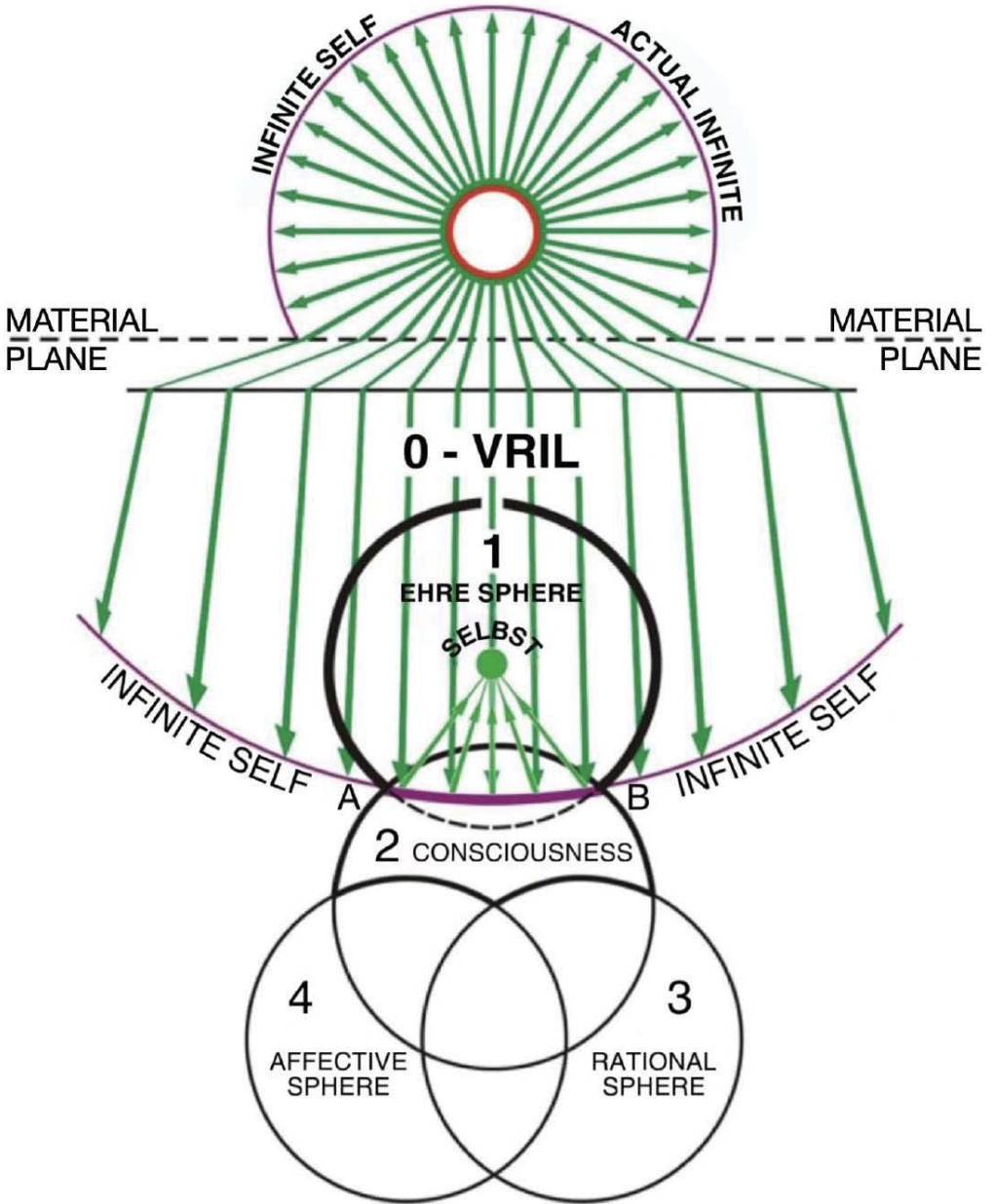

\overline{AB} = SYMBOL OF THE ORIGIN

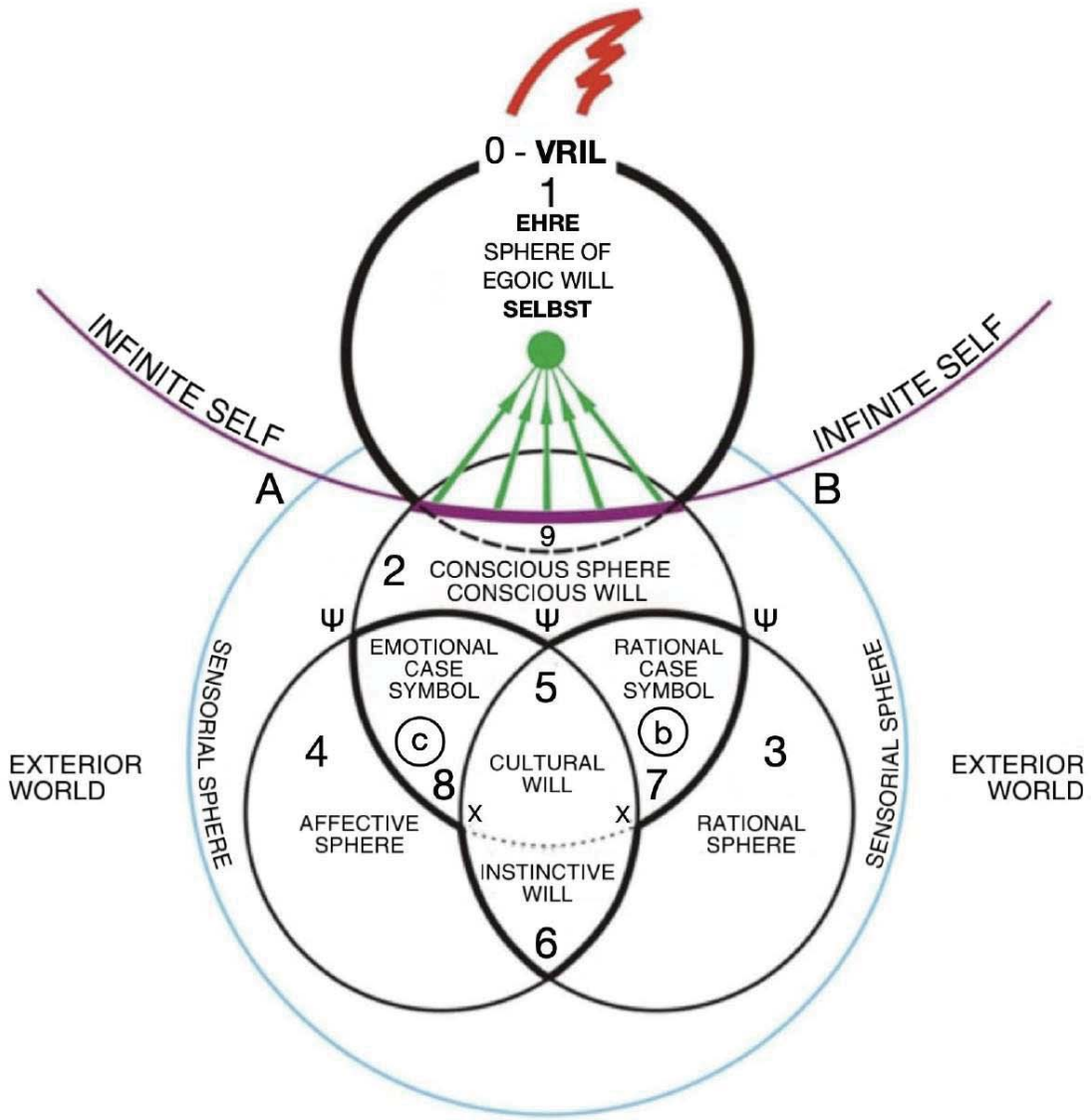

PSYCHIC STRUCTURE OF THE AWAKENED VIRYA

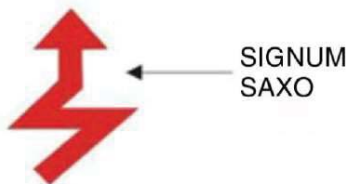
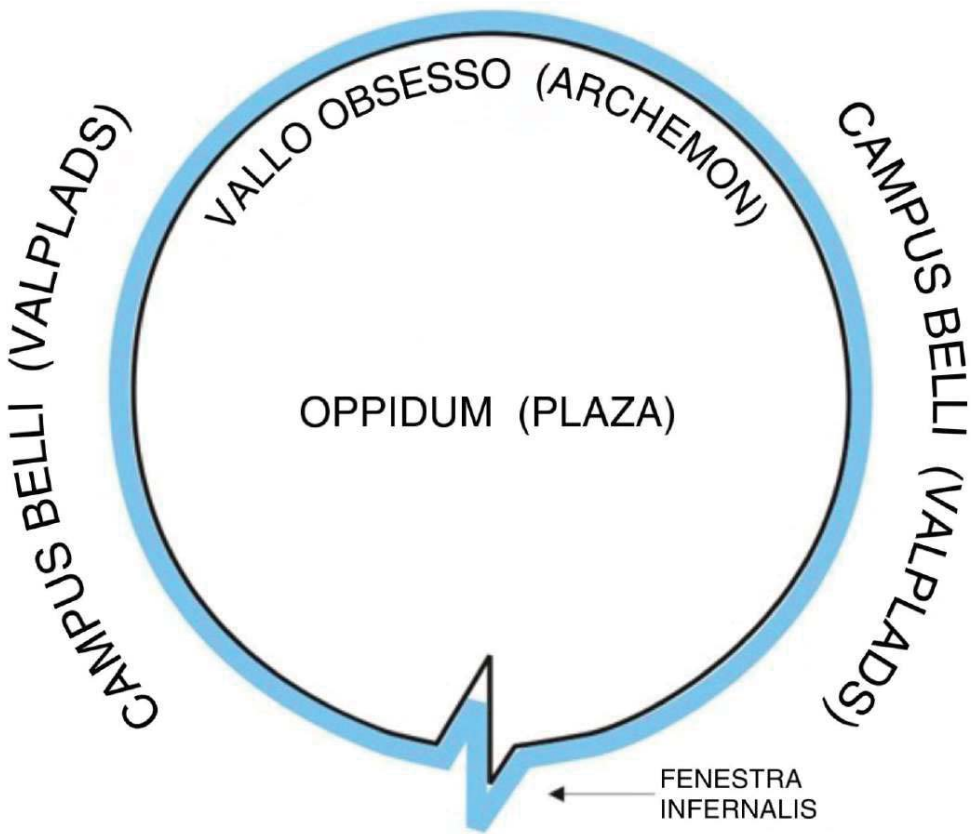

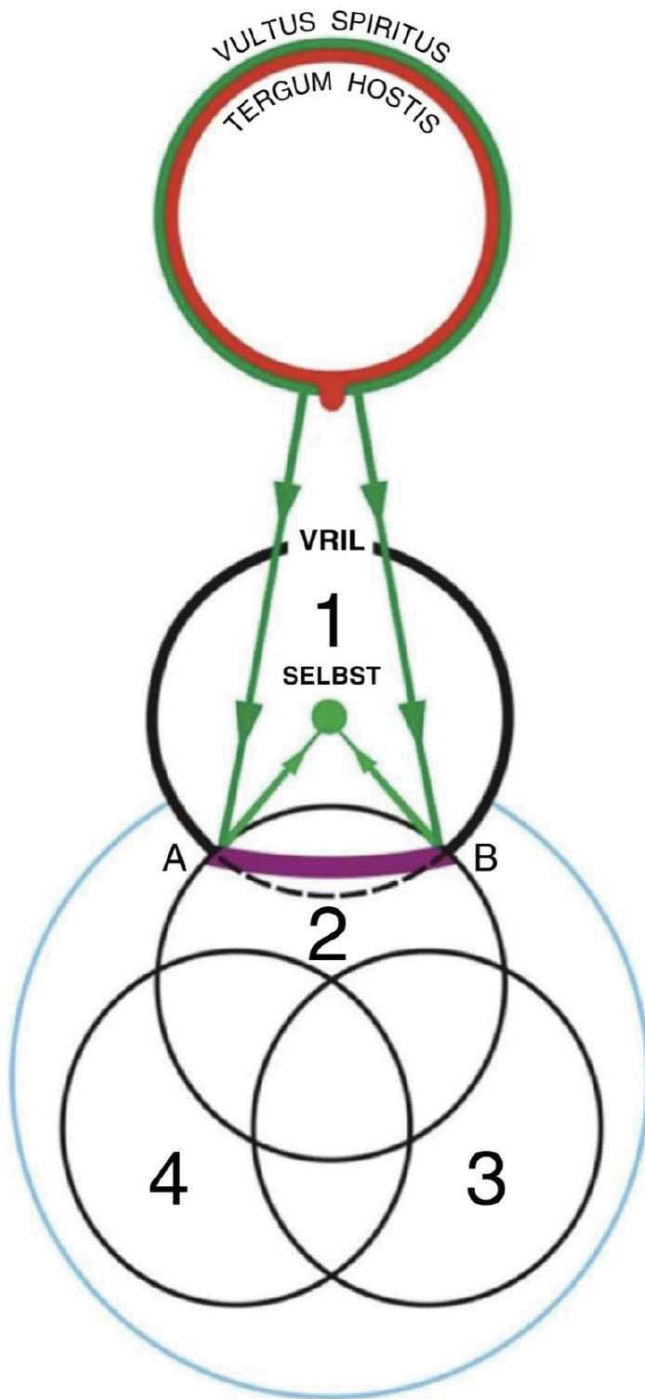

**THE AWAKENED SELF, FROM THE SELBST,
SEEKS THE ETERNAL SPIRIT IN THE VRIL**

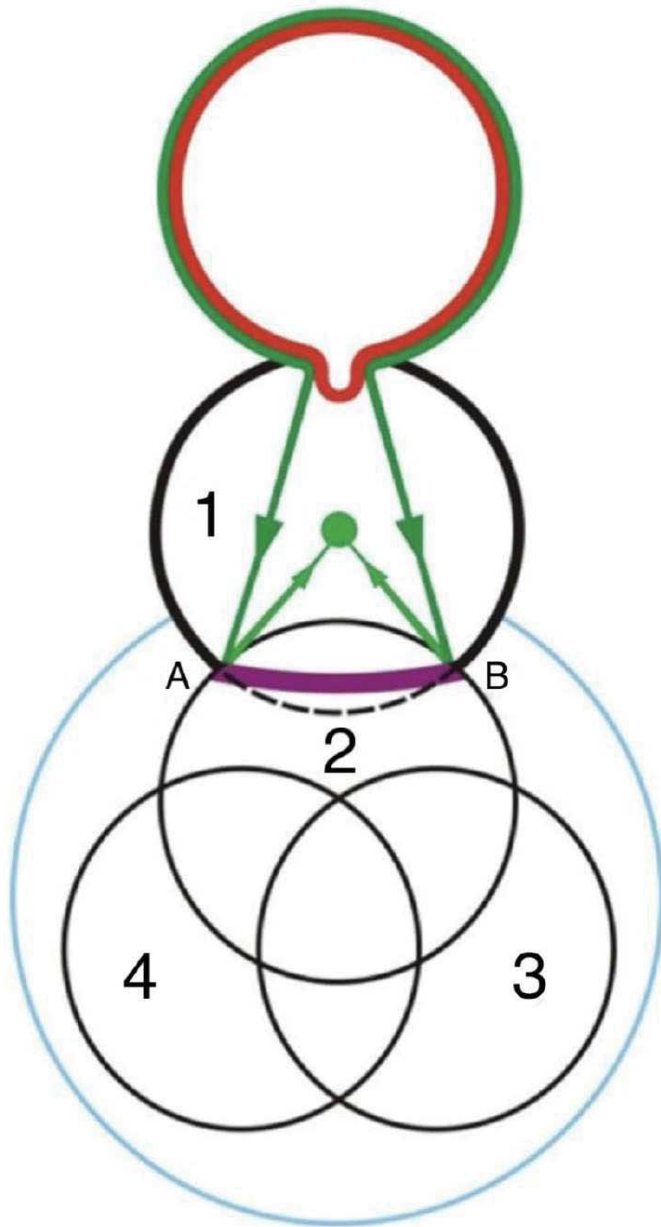

THE REVERTED SPHERE SPIRIT BEGINS TO REORIENT ITSELF AND APPROACHES THE AWAKENED SELF, AND THE AWAKENED SELF PROCURES THE MANIFESTATION OF THE TERGUM HOSTIS

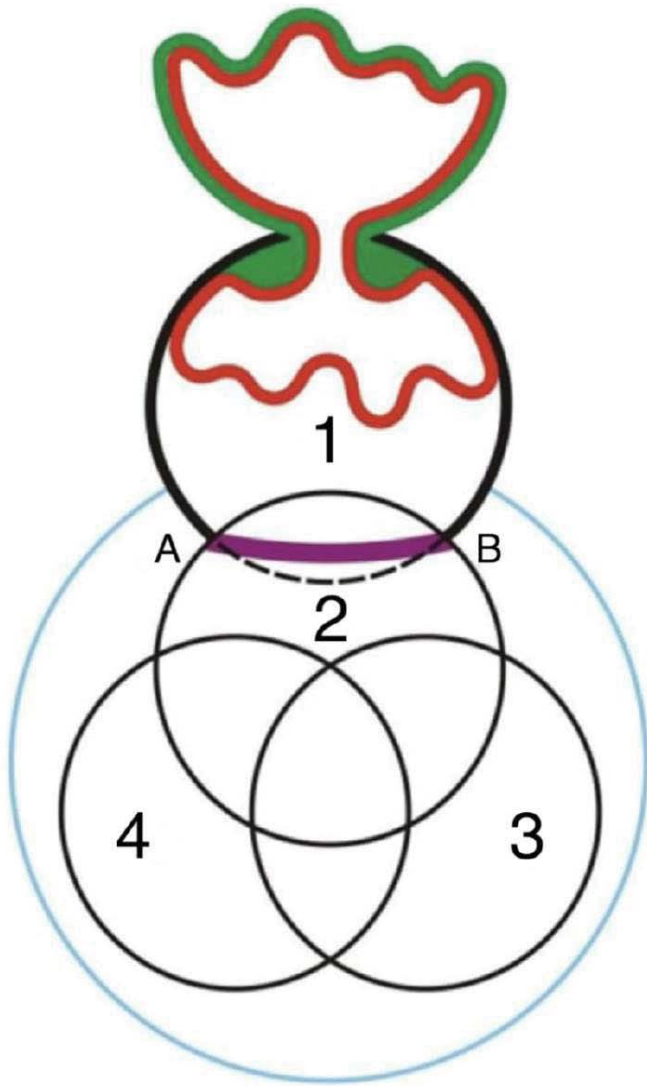

HERE IS THE POWER OF THE VRIL: THE TERGUM
HOSTIS MANIFESTS IN THE MICROCOSM AND THE
SPIRIT RETURNS TO NORMAL, ANNULING THE
ORIGINAL TREASON. THE AWAKENED VIRYA
EXPERIENCES THE ESSENTIAL HOSTILITY:
THE BERSERKER FURY

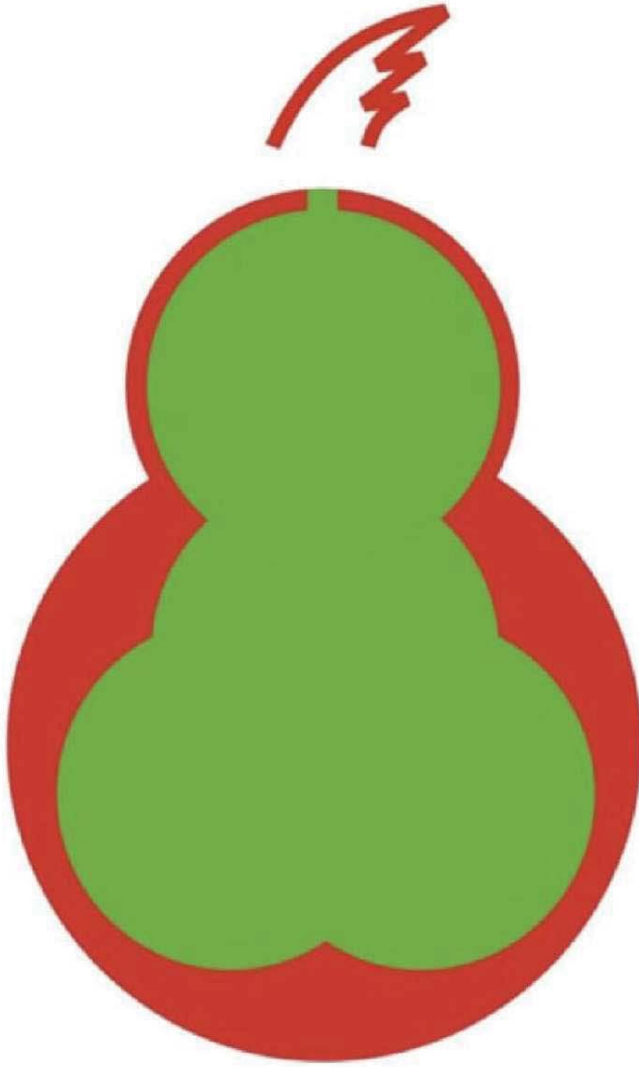

**THE HYPERBOREAN SPIRIT HAS RETURNED TO
NORMALITY, TRANSMUTING THE AWAKENED
VIRYA INTO A BERSERKIR SIDDHA. THE BODY OF
THE SIDDHA IS COATED BY THE TERGUM HOSTIS
WHILE THE INTERIOR STRUCTURES CONSTITUTE
THE VULTUS SPIRITUS**

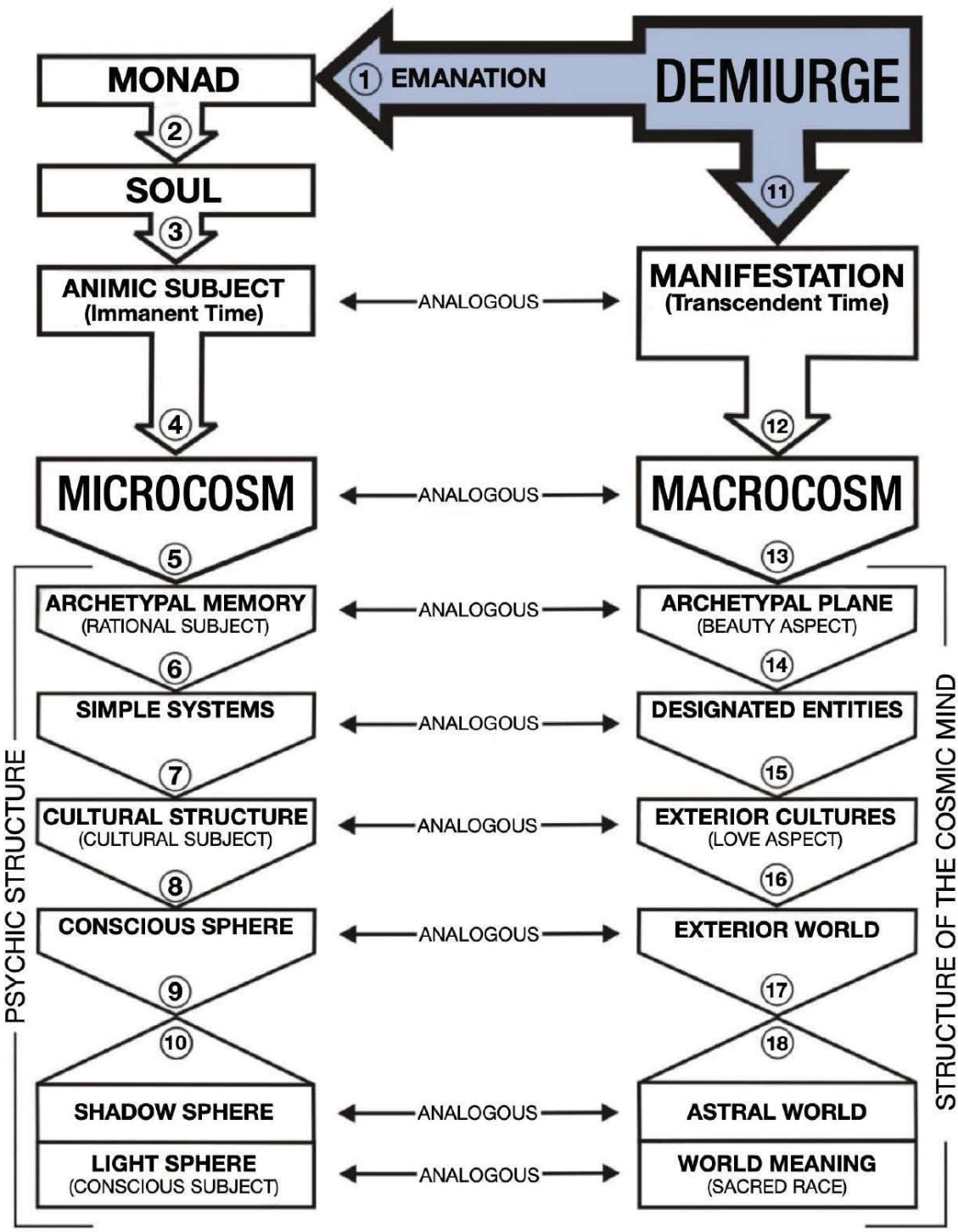

ANALOGICAL CORRESPONDENCES BETWEEN MICRO AND MACROCOSMOS

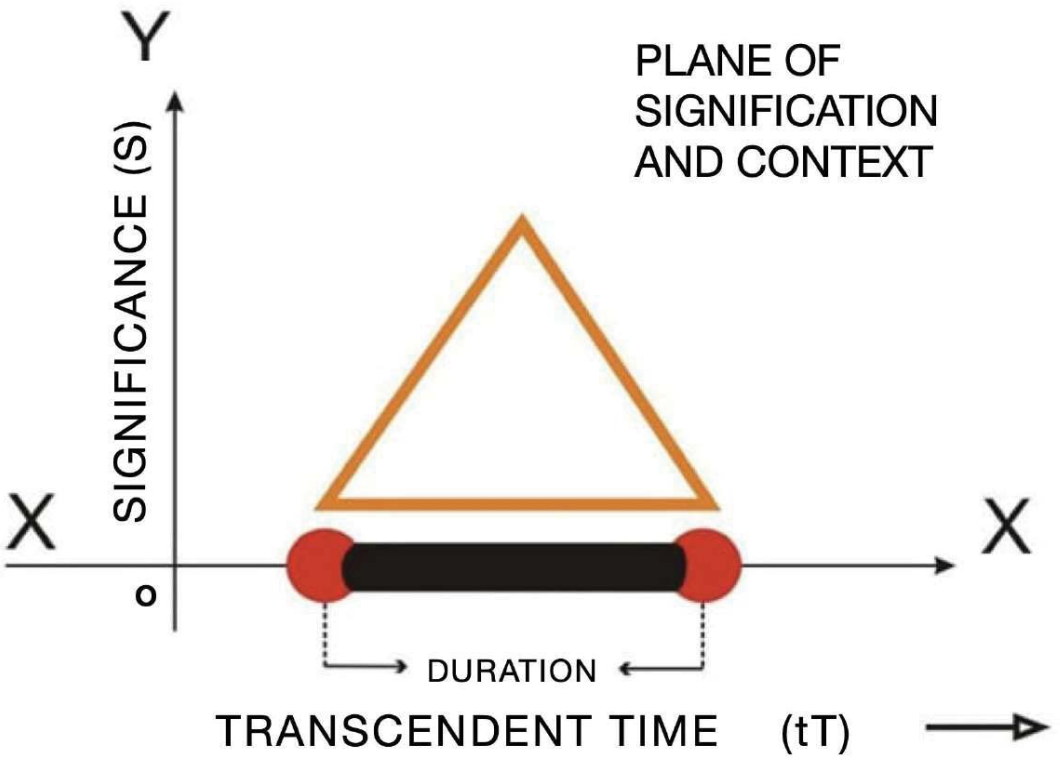

(X) ARCHETYPE (X)

ENTELECHY

(X'X')

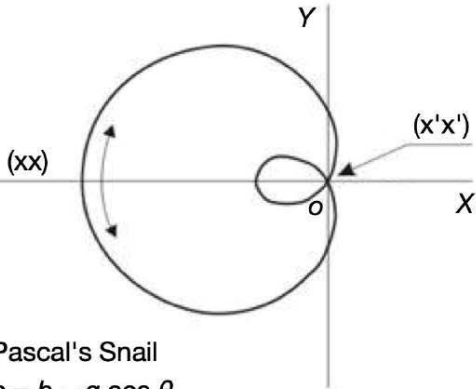

Pascal's Snail
 $\rho = b - a \cos \theta$
 (In the figure, $b < a$).

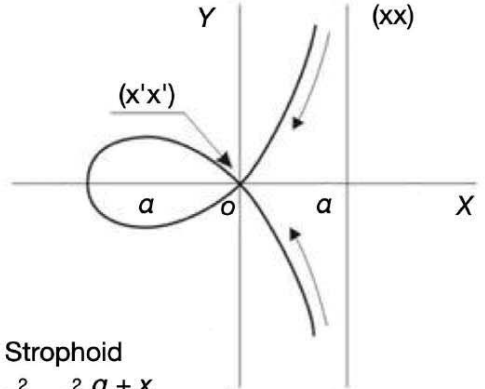

Strophoid
 $y^2 = x^2 \frac{a+x}{a-x}$

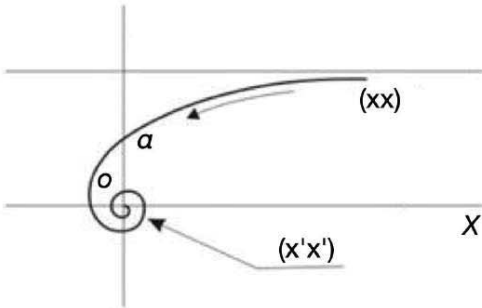

Hyperbolic spiral
 $\rho \theta = a$

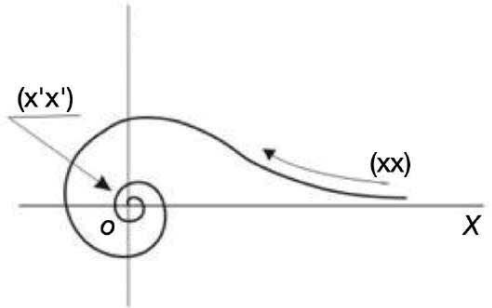

Lituus
 $\rho^2 \theta = a^2$

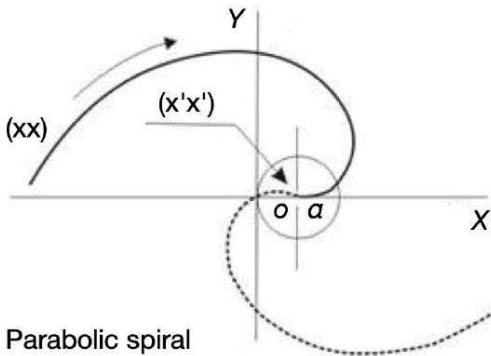

Parabolic spiral
 $(\rho - a)^2 = 4 a c \theta$

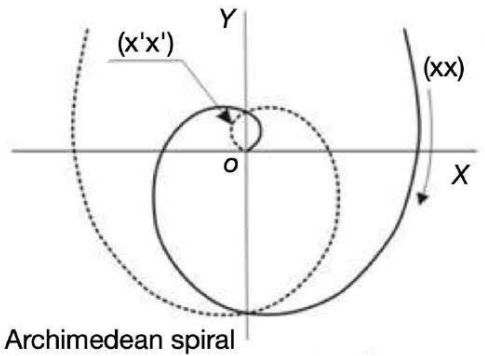

Archimedean spiral
 $\rho = a \theta$

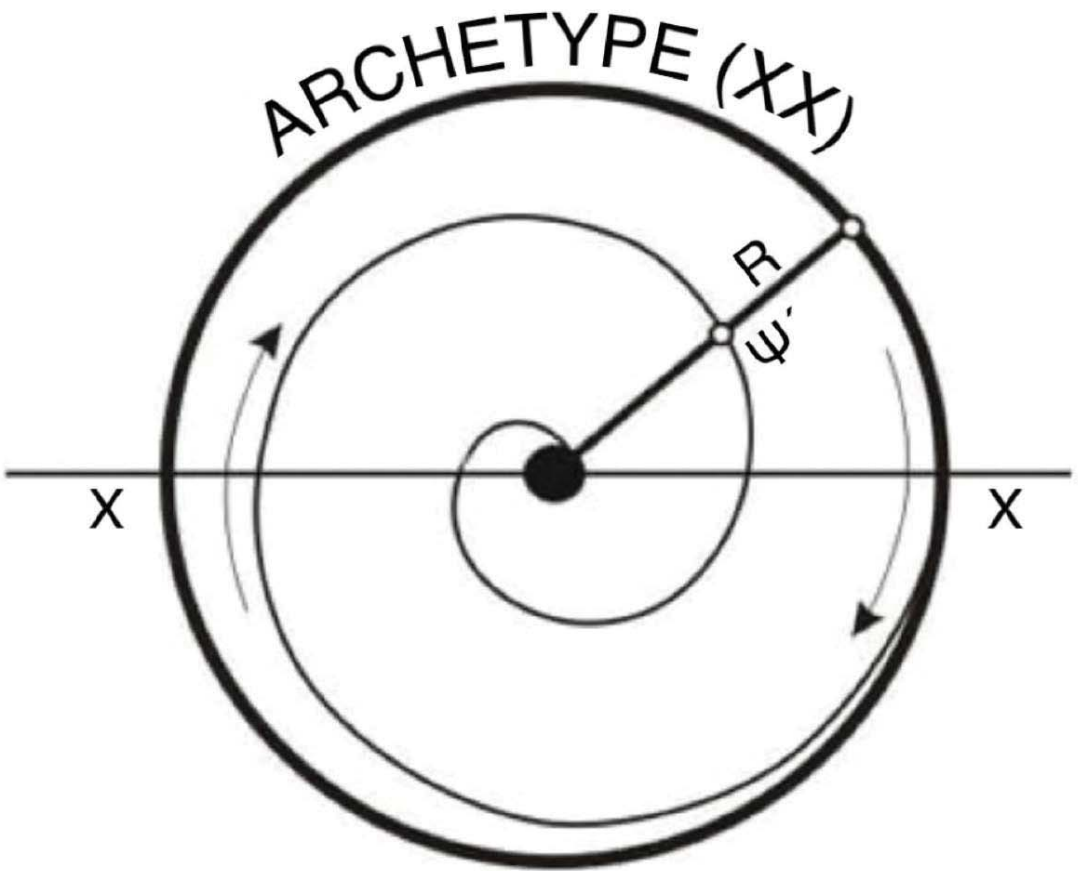

LOGARITHMIC SPIRAL

$$\rho = e^{a\theta}, \text{ or,}$$
$$\log \rho = a\theta$$

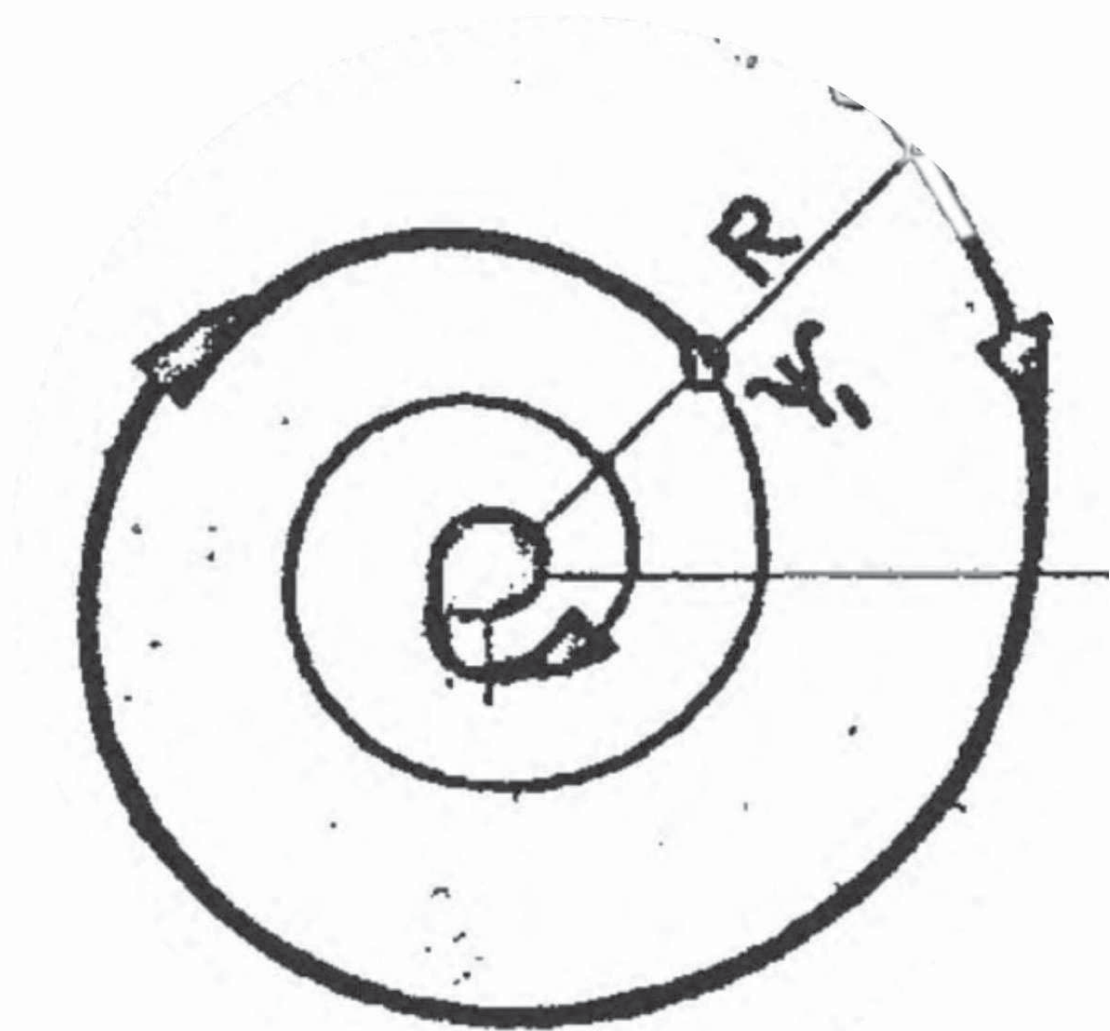

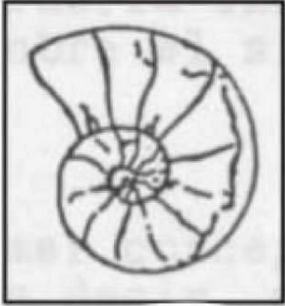

NAUTILUS



GYROCERAS



NAUTILUS (cross-section)

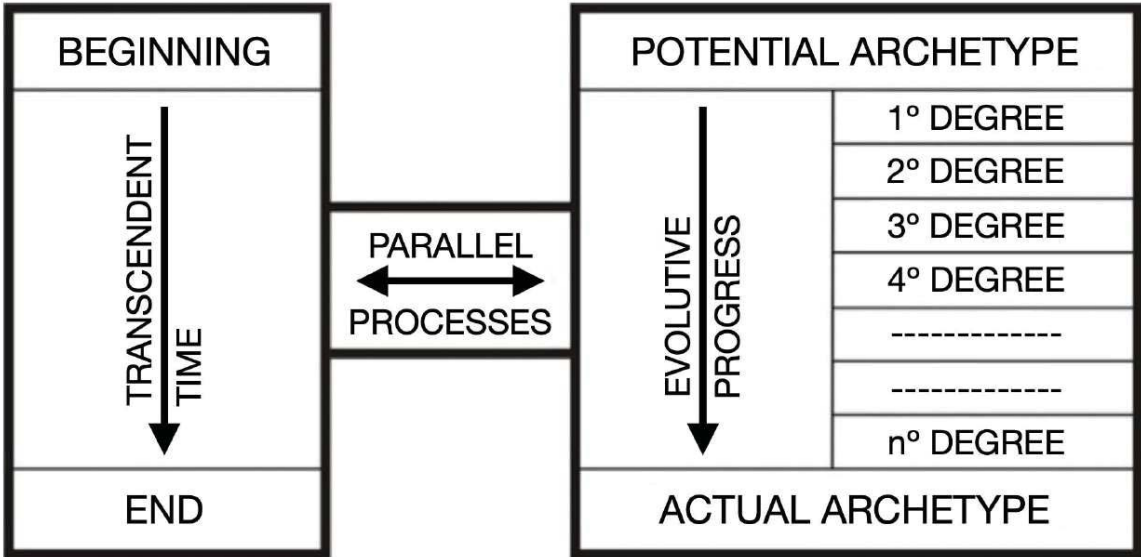

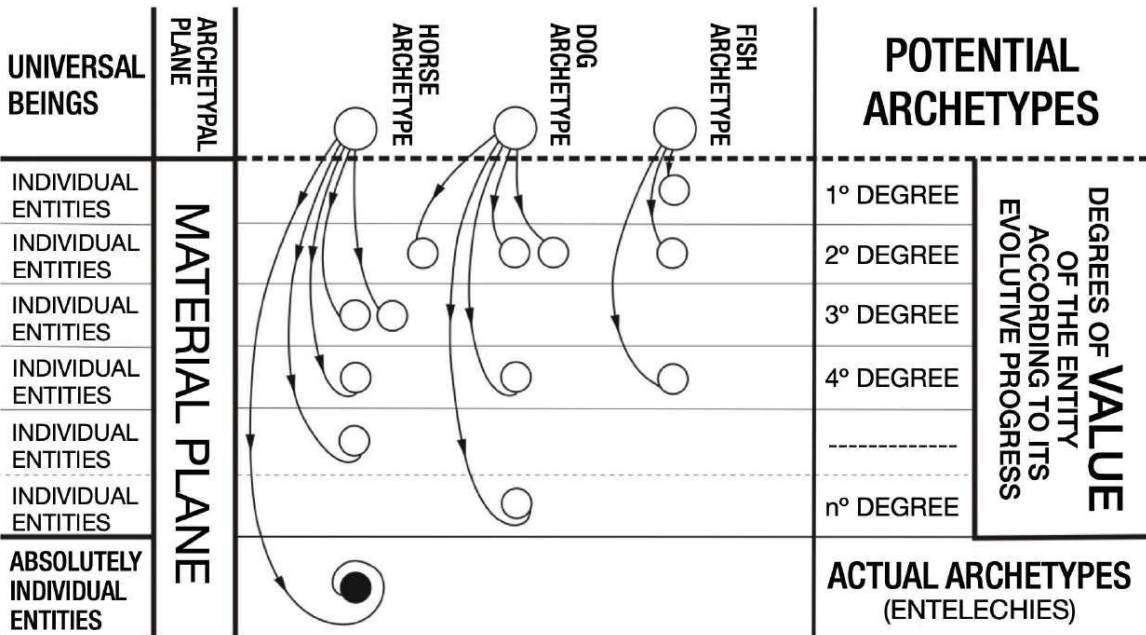

ANIMAL GENUS

HORSE SPECIES

DOG SPECIES

FISH SPECIES

RATIONAL CLASSIFICATION

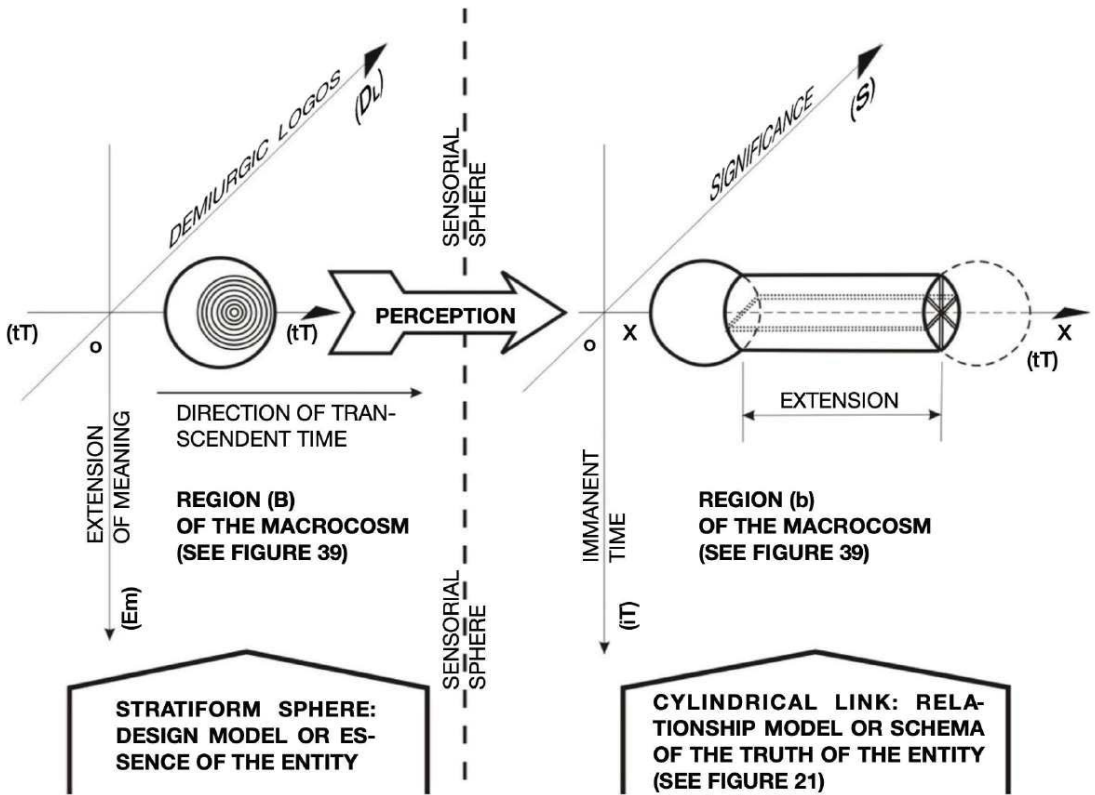

UNFOLDED DESIGN

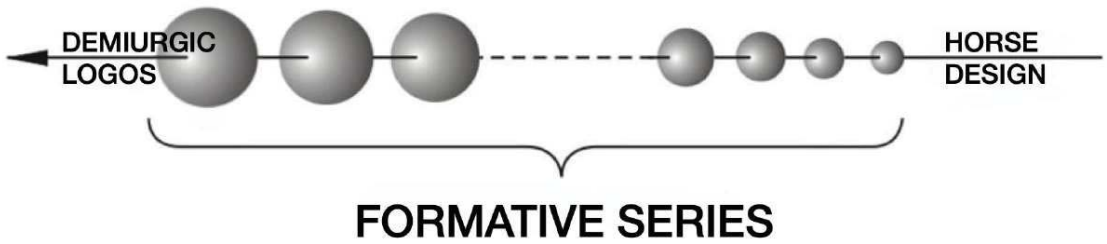

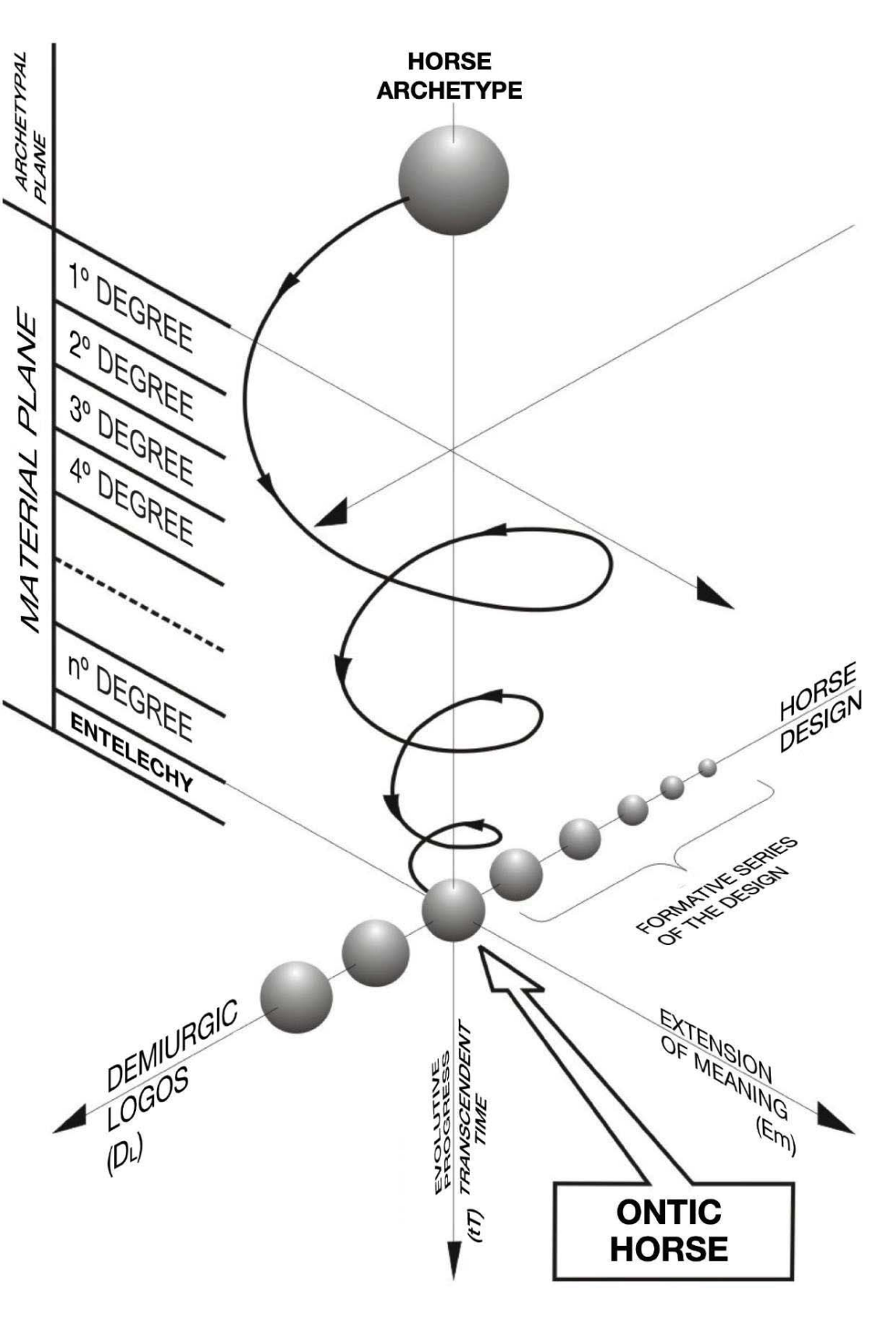

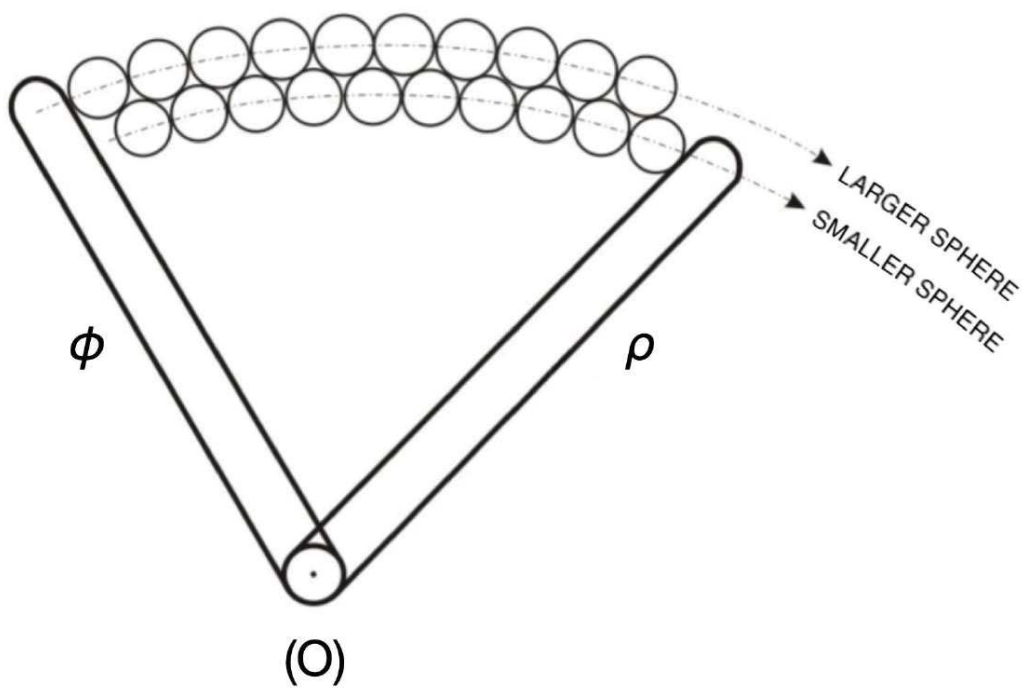

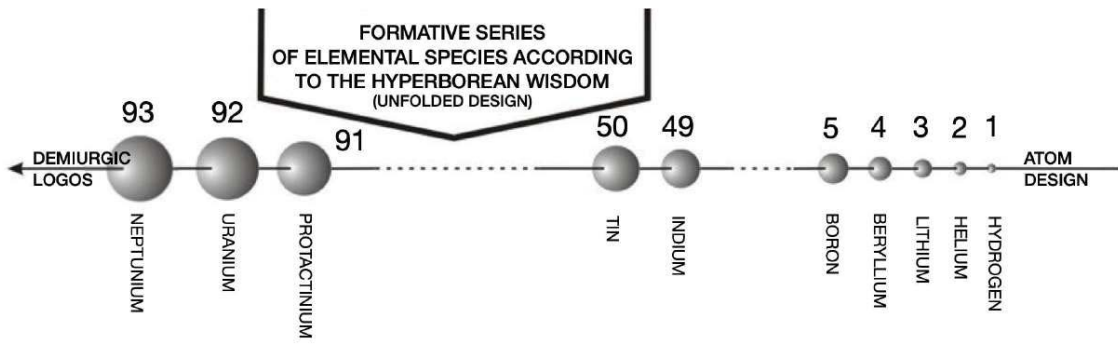

PERIODIC TABLE OF ELEMENTAL SPECIES ACCORDING TO PHYSICS

1 H Hydrogen 1.008	2 He Helium 4.003	<h1 style="margin: 0;">PERIODIC TABLE OF ELEMENTAL SPECIES ACCORDING TO PHYSICS</h1>																13 B Boron 10.811	14 C Carbon 12.011	15 N Nitrogen 14.007	16 O Oxygen 15.999	17 F Fluorine 18.998	18 Ne Neon 20.180		
3 Li Lithium 6.941	4 Be Beryllium 9.012																	5 Al Aluminum 26.982	6 Si Silicon 28.086	7 P Phosphorus 30.974	8 S Sulfur 32.066	9 Cl Chlorine 35.453	10 Ar Argon 39.948		
11 Na Sodium 22.990	12 Mg Magnesium 24.305	3 IIIB		4 IVB		5 VB		6 VIB		7 VIIB		8 VIII 8		9 VIII 8		10 VIII 8		11 IB	12 IIB	13 Al Aluminum 26.982	14 Si Silicon 28.086	15 P Phosphorus 30.974	16 S Sulfur 32.066	17 Cl Chlorine 35.453	18 Ar Argon 39.948
19 K Potassium 39.098	20 Ca Calcium 40.078	21 Sc Scandium 44.956	22 Ti Titanium 47.867	23 V Vanadium 50.942	24 Cr Chromium 51.996	25 Mn Manganese 54.938	26 Fe Iron 55.845	27 Co Cobalt 58.933	28 Ni Nickel 58.693	29 Cu Copper 63.546	30 Zn Zinc 65.38	31 Ga Gallium 69.723	32 Ge Germanium 72.631	33 As Arsenic 74.922	34 Se Selenium 78.971	35 Br Bromine 79.904	36 Kr Krypton 83.798								
37 Rb Rubidium 85.468	38 Sr Strontium 87.62	39 Y Yttrium 88.906	40 Zr Zirconium 91.224	41 Nb Niobium 92.906	42 Mo Molybdenum 95.95	43 Tc Technetium 98.907	44 Ru Ruthenium 101.07	45 Rh Rhodium 102.906	46 Pd Palladium 106.42	47 Ag Silver 107.868	48 Cd Cadmium 112.414	49 In Indium 114.818	50 Sn Tin 118.711	51 Sb Antimony 121.760	52 Te Tellurium 127.6	53 I Iodine 126.904	54 Xe Xenon 131.294								
55 Cs Cesium 132.905	56 Ba Barium 137.328	57-71	72 Hf Hafnium 178.49	73 Ta Tantalum 180.948	74 W Tungsten 183.84	75 Re Rhenium 186.207	76 Os Osmium 190.23	77 Ir Iridium 192.217	78 Pt Platinum 195.085	79 Au Gold 196.967	80 Hg Mercury 200.592	81 Tl Thallium 204.383	82 Pb Lead 207.2	83 Bi Bismuth 208.980	84 Po Polonium (209)	85 At Astatine 209	86 Rn Radon 222.018								
87 Fr Francium 223.020	88 Ra Radium 226.025	89-103	104 Rf Rutherfordium (261)	105 Db Dubnium (262)	106 Sg Seaborgium (264)	107 Bh Bohrium (264)	108 Hs Hassium (269)	109 Mt Meitnerium (278)	110 Ds Darmstadtium (281)	111 Rg Roentgenium (289)	112 Cn Copernicium (285)	113 Nh Nihonium (286)	114 Fl Flerovium (289)	115 Mc Moscovium (289)	116 Lv Livermorium (293)	117 Ts Tennessine (294)	118 Og Oganesson (294)								

Lanthanide Series	57 La Lanthanum 138.905	58 Ce Cerium 140.116	59 Pr Praseodymium 140.908	60 Nd Neodymium 144.242	61 Pm Promethium 144.913	62 Sm Samarium 150.36	63 Eu Europium 151.964	64 Gd Gadolinium 157.25	65 Tb Terbium 158.925	66 Dy Dysprosium 162.500	67 Ho Holmium 164.930	68 Er Erbium 167.259	69 Tm Thulium 168.934	70 Yb Ytterbium 173.055	71 Lu Lutetium 174.967
Actinide Series	89 Ac Actinium 227.028	90 Th Thorium 232.038	91 Pa Protactinium 231.036	92 U Uranium 238.029	93 Np Neptunium 237.048	94 Pu Plutonium 244.064	95 Am Americium 243.061	96 Cm Curium 247.070	97 Bk Berkelium 247.070	98 Cf Californium 251.080	99 Es Einsteinium (264)	100 Fm Fermium 257.095	101 Md Mendelevium 261	102 No Nobelium 259.101	103 Lr Lawrencium (262)

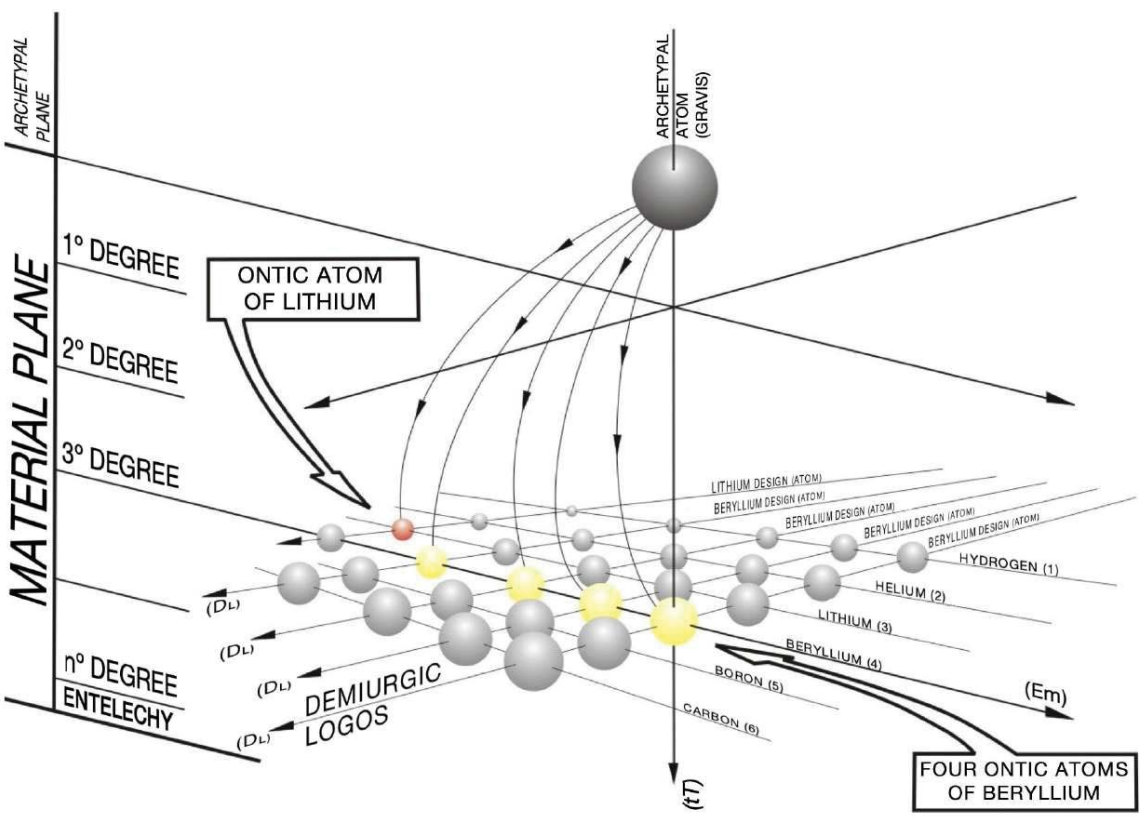

HIERARCHICAL RELATIONSHIP BETWEEN THE SNAIL DESIGN AND THE SERPENT DESIGN

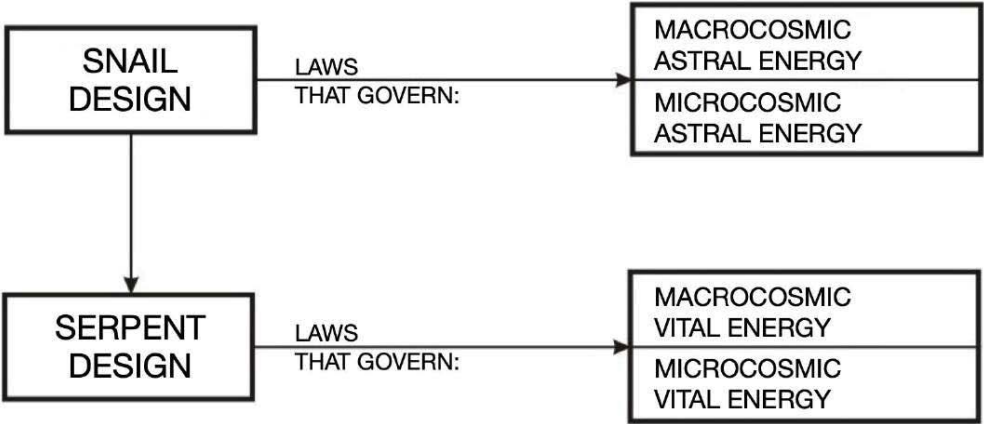

(a)

STRUCTURAL ANALOGY, BY MEANS OF THE UNFOLDED DESIGN MODEL, OF THE HIERARCHICAL RELATIONSHIP BETWEEN THE SNAIL DESIGN AND THE SERPENT

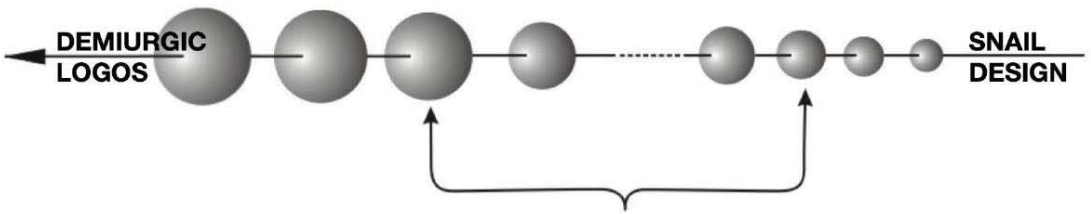

(b)

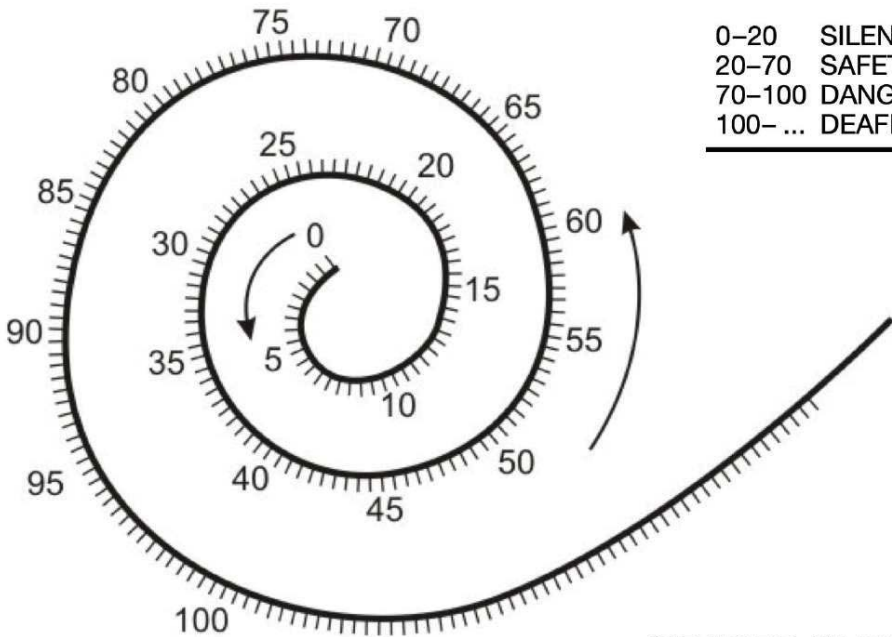

0-20 SILENT AREA
 20-70 SAFETY AREA
 70-100 DANGER AREA
 100- ... DEAFNESS AREA

By courtesy of Dr. Harvey Fletcher

GRADED IN DECIBELS

CONVENTIONAL SCHEMA OF THE COCHLEA

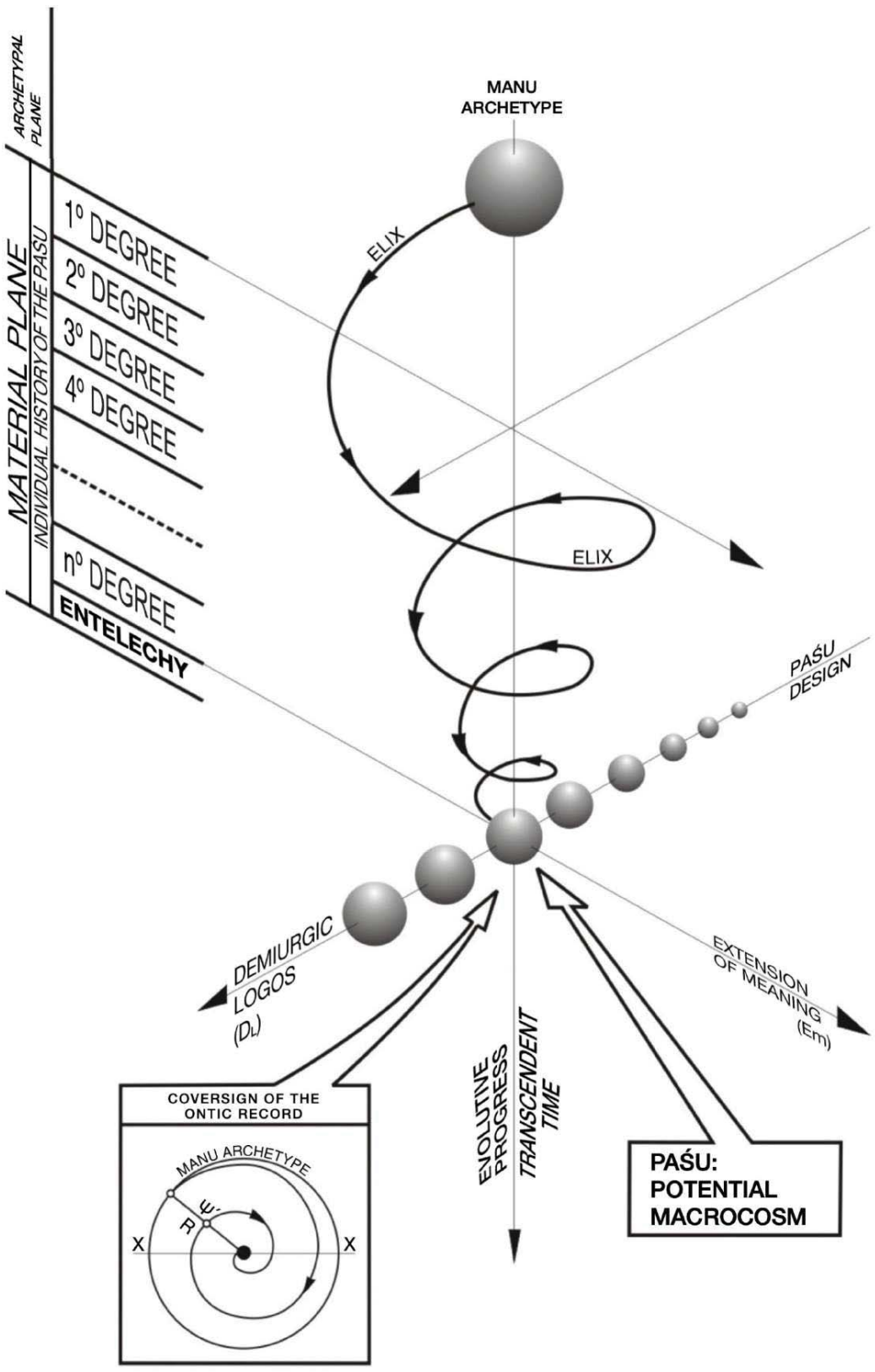

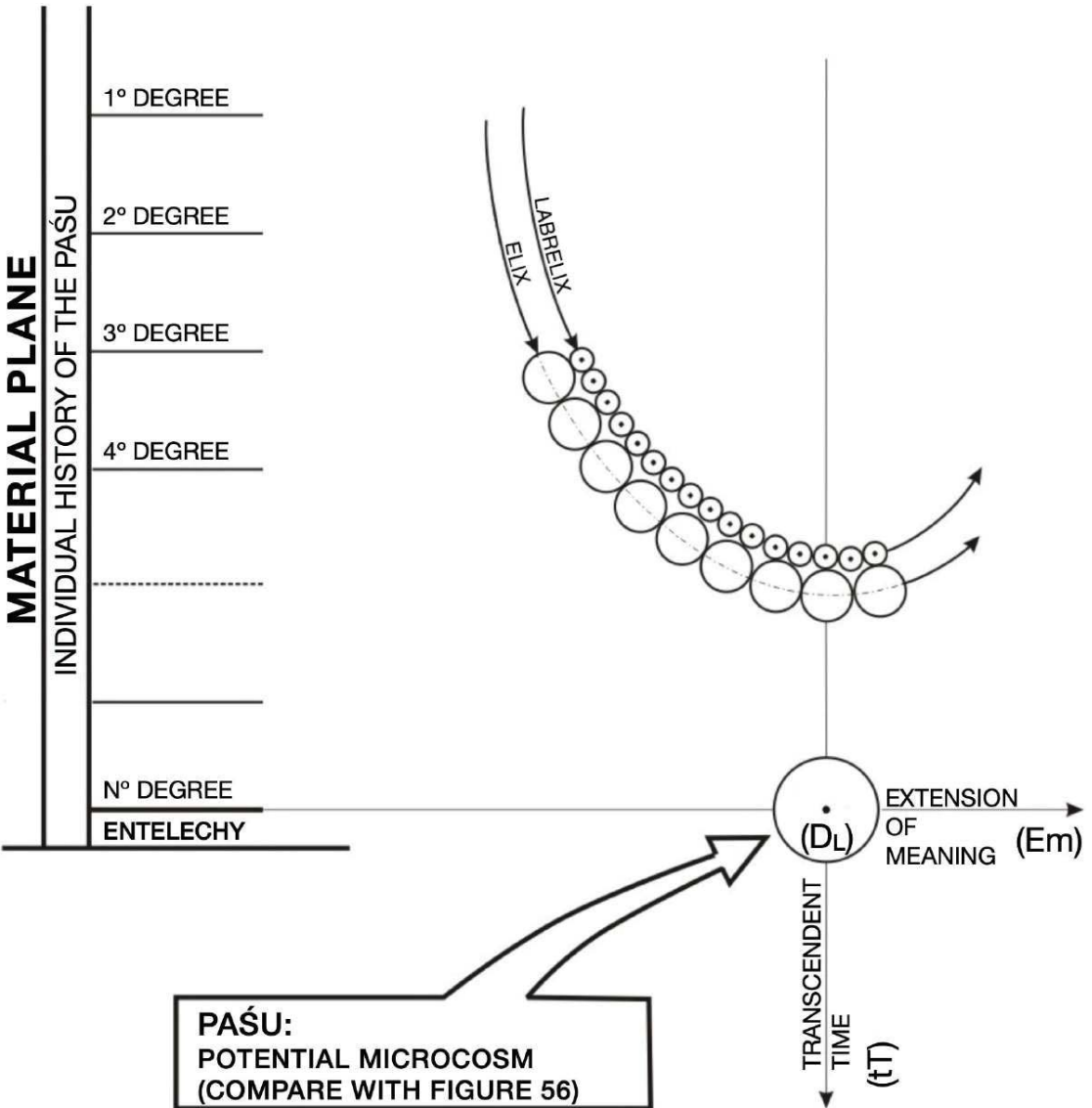

TETRARCH POINT OF THE LABRELIX CURVE

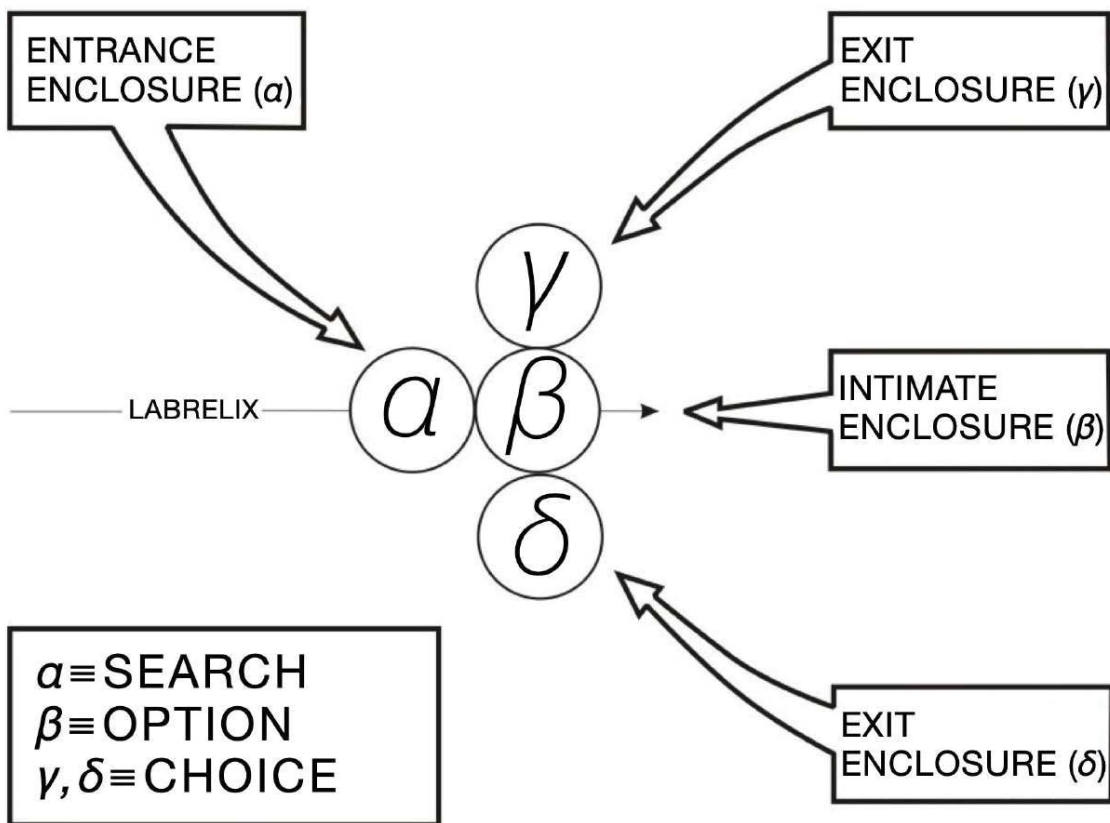

ENERGETIC SCHEMATA ALIGNED ALONG THE AXIS OF TRANSCENDENT TIME (τT)

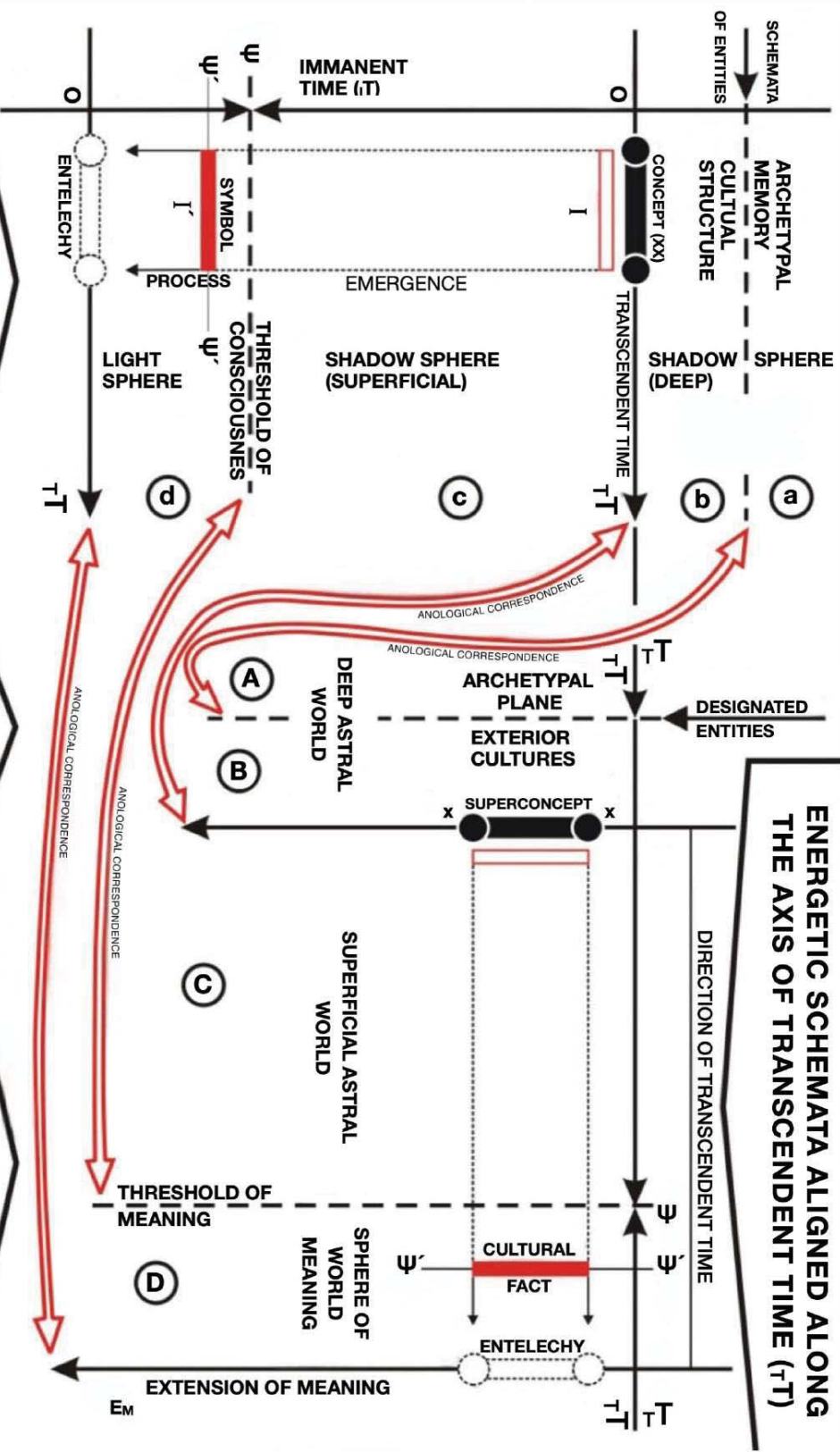

MICROCOSMIC PROCESS OF THE CONSCIOUS REPRESENTATION OF A CONCEPT (XX) IN THE LIGHT SPHERE (see figure 24).

THE CURVED ARROWS INDICATE THE ANALOGICAL CORRESPONDENCES BETWEEN MICRO AND MACROCOSMIC PROCESSES.

MICROCOSMIC PROCESS OF THE CONSCIOUS REPRESENTATION OF A SUPERCONCEPT (XX) OR EXTERIOR CULTURAL SYSTEM IN THE SPHERE OF WORLD MEANING (see Figure 24).

PAŚU:
 POTENTIAL MICROCOSM
 (COMPARE WITH FIG. 56)

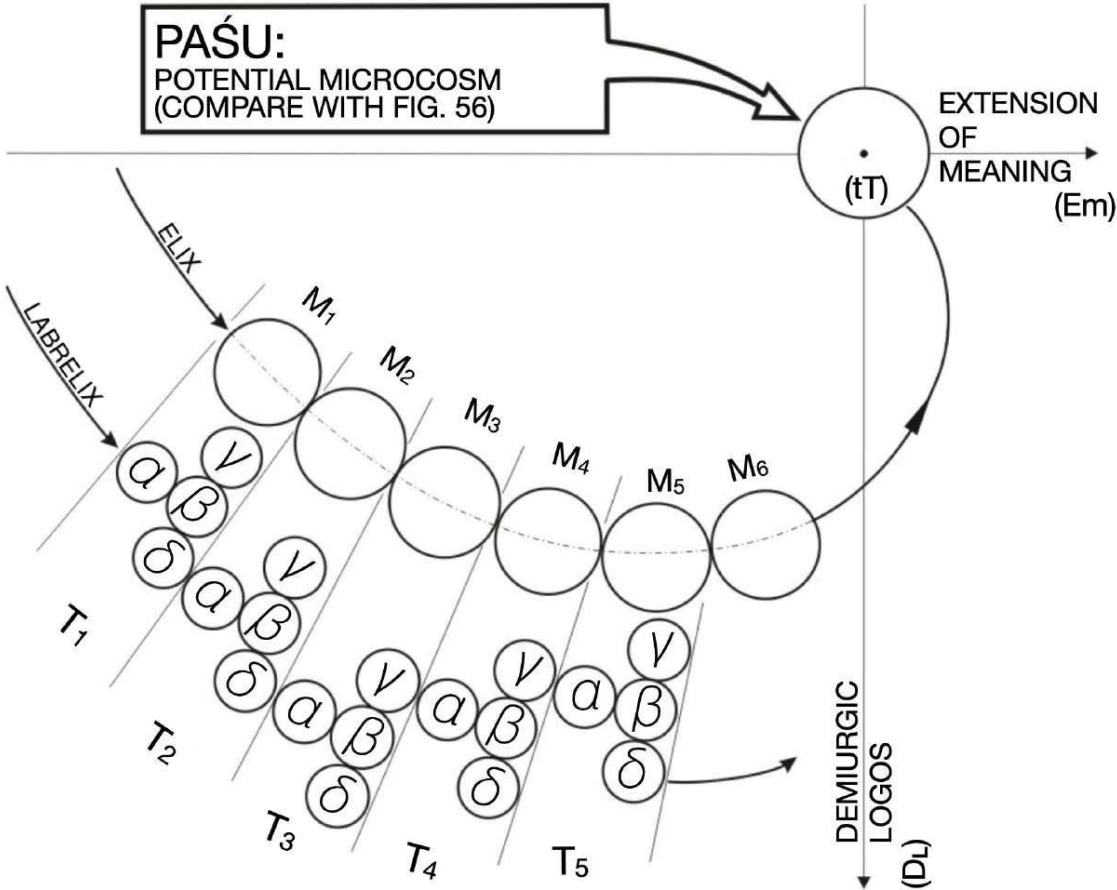

TETRARCH

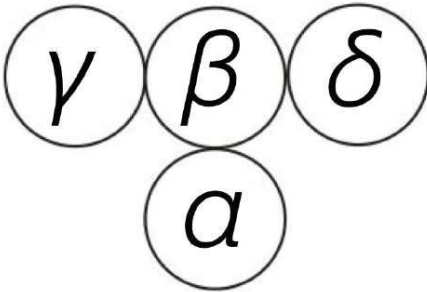

GIBUR RUNE

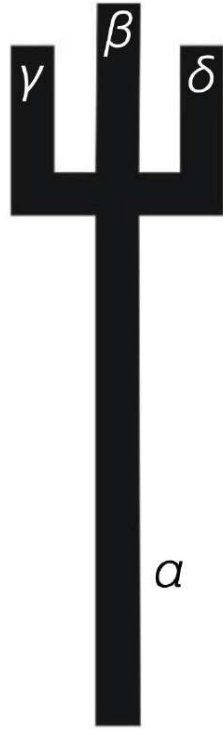

ANALOGICAL
CORRESPONDENCES
BETWEEN THE
TETRARCH POINT AND
THE GIBUR RUNE



THE **GIBUR** RUNE ARRAYED AS A
"TRIDENT OF POSEIDON"

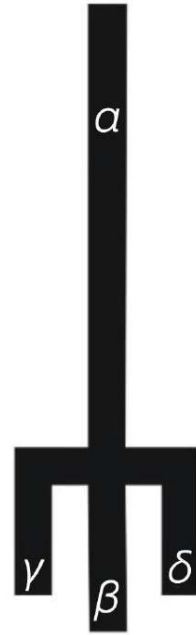

THE **GIBUR** RUNE ARRAYED AS A
"SWORD OF WOTAN"

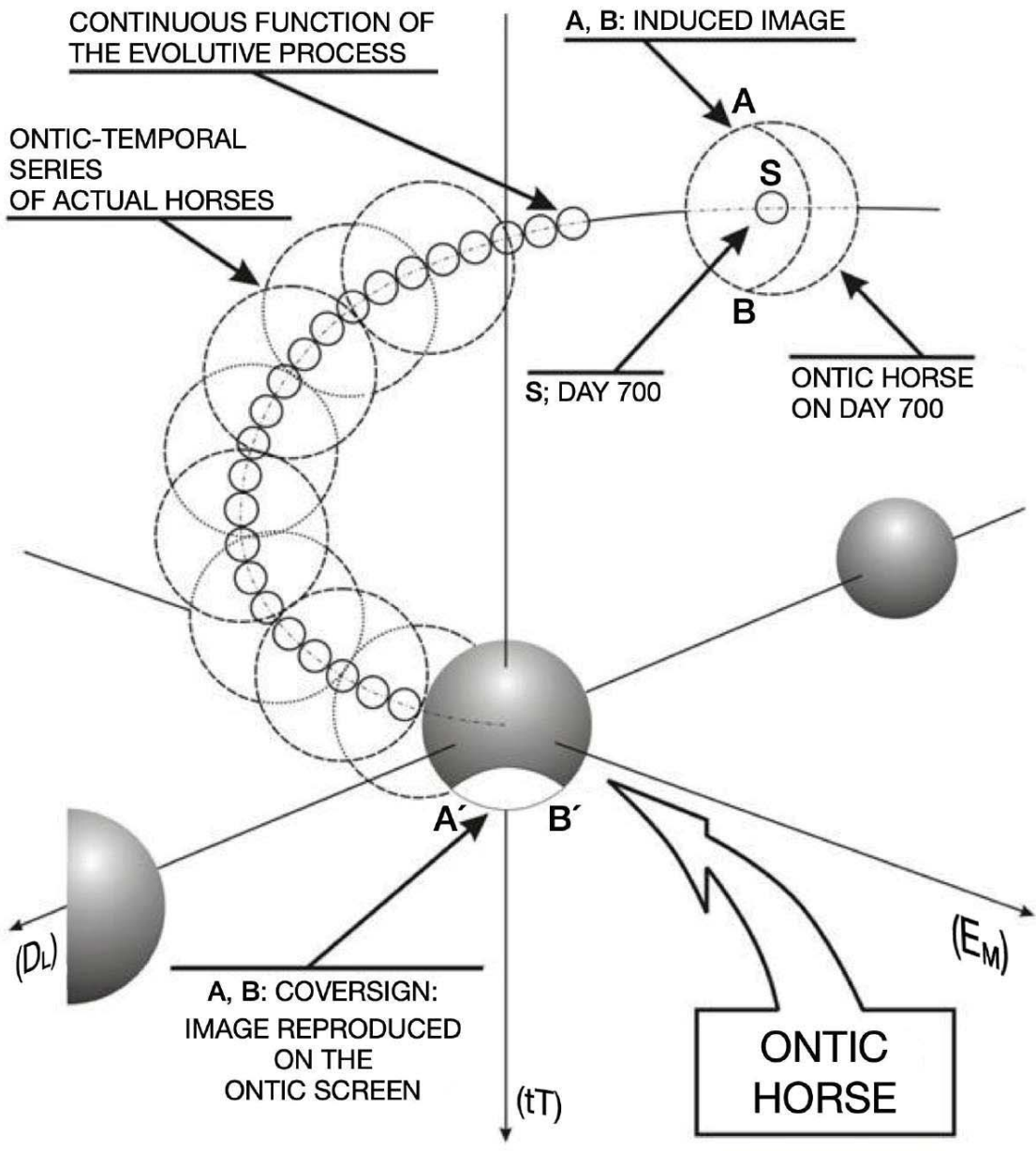

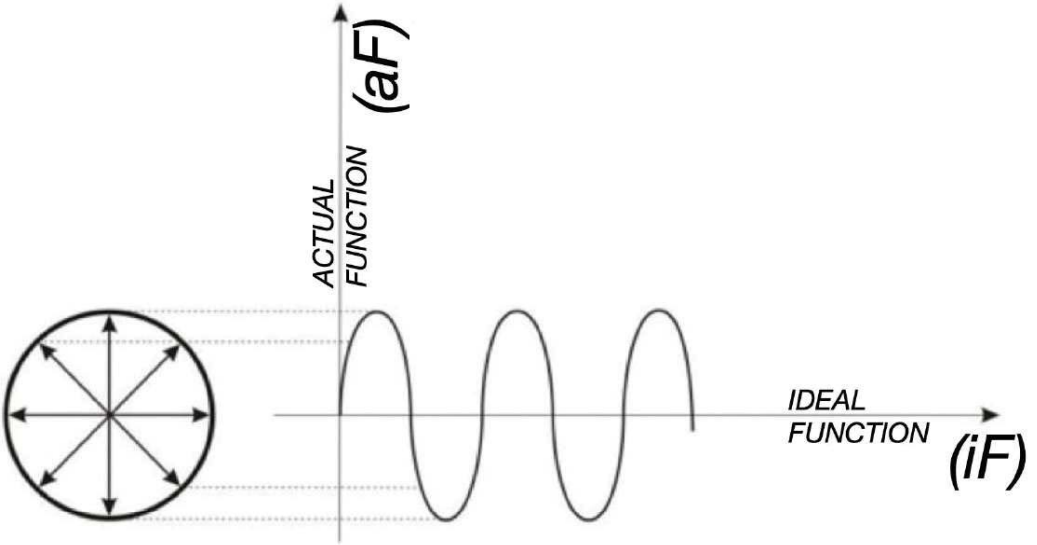

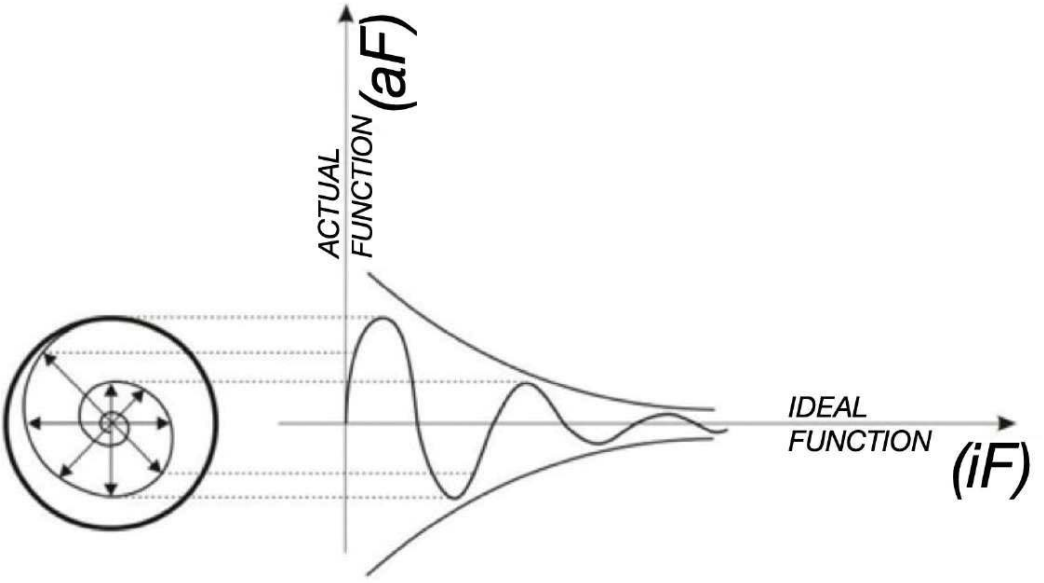

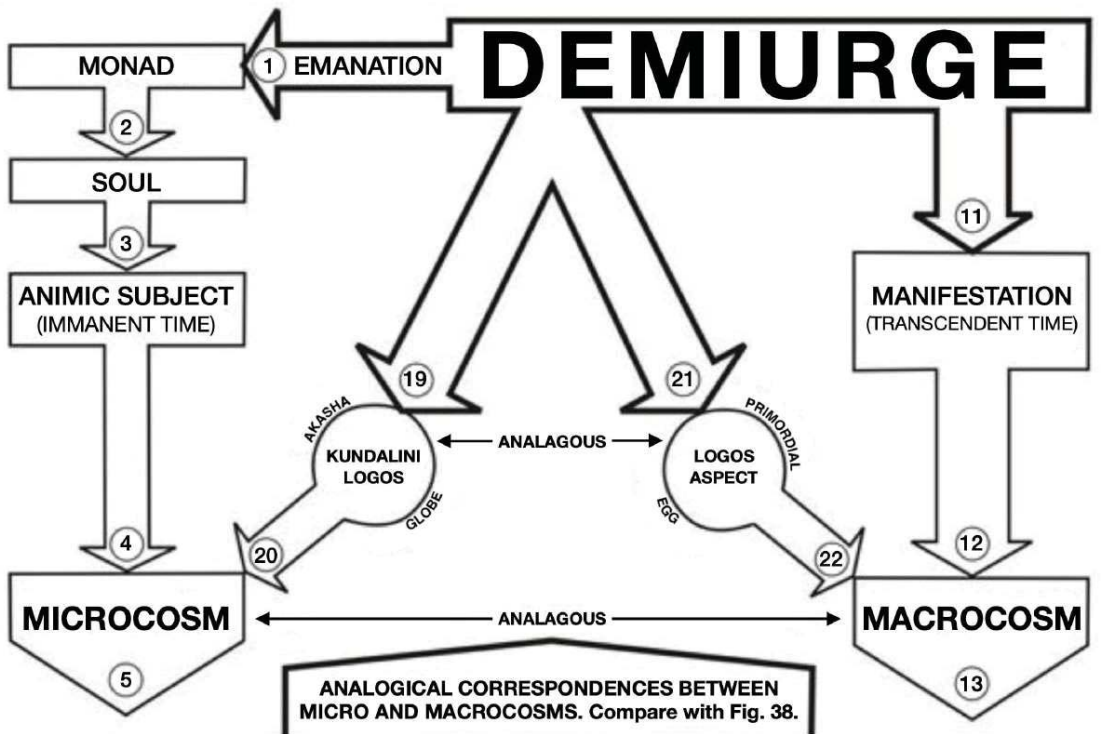

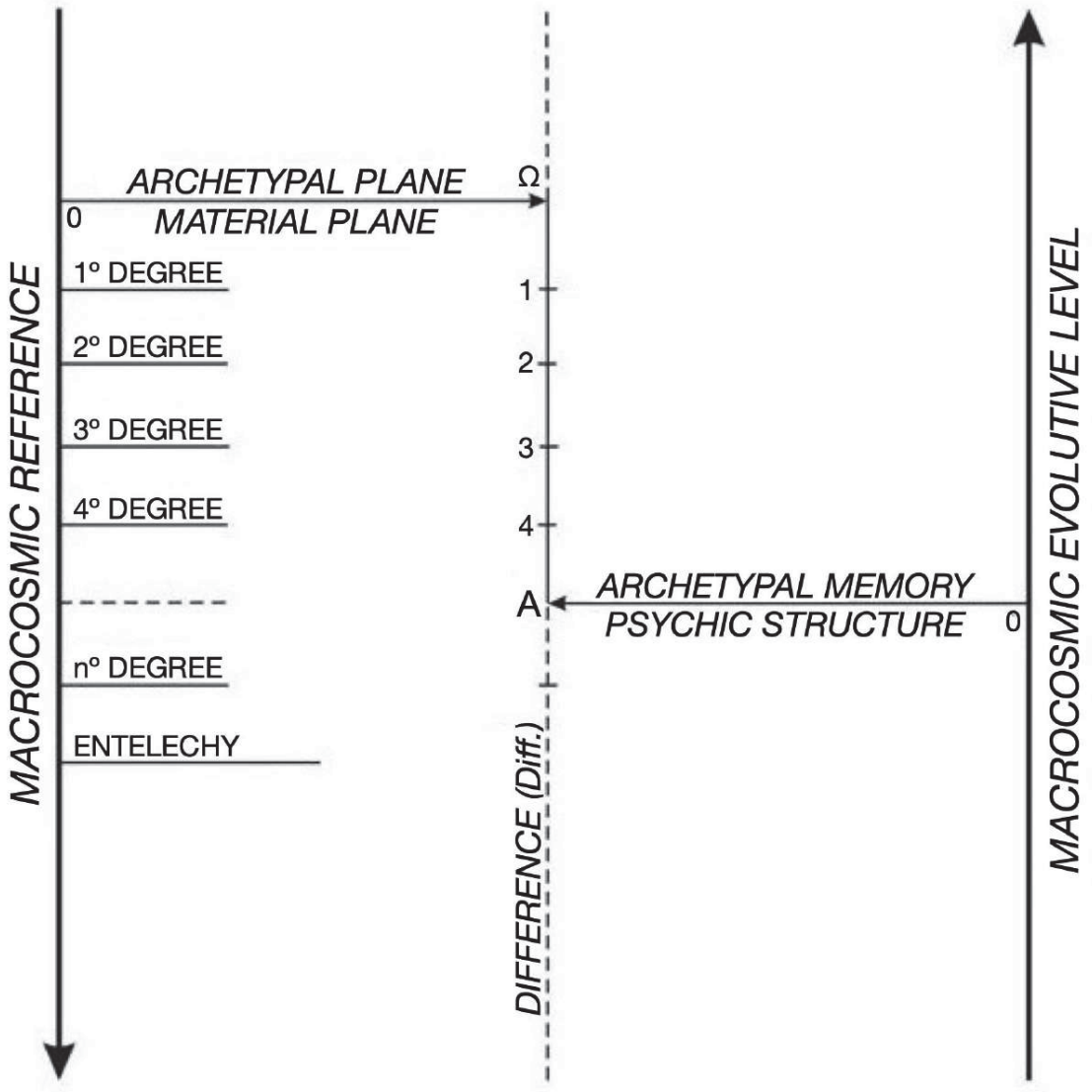

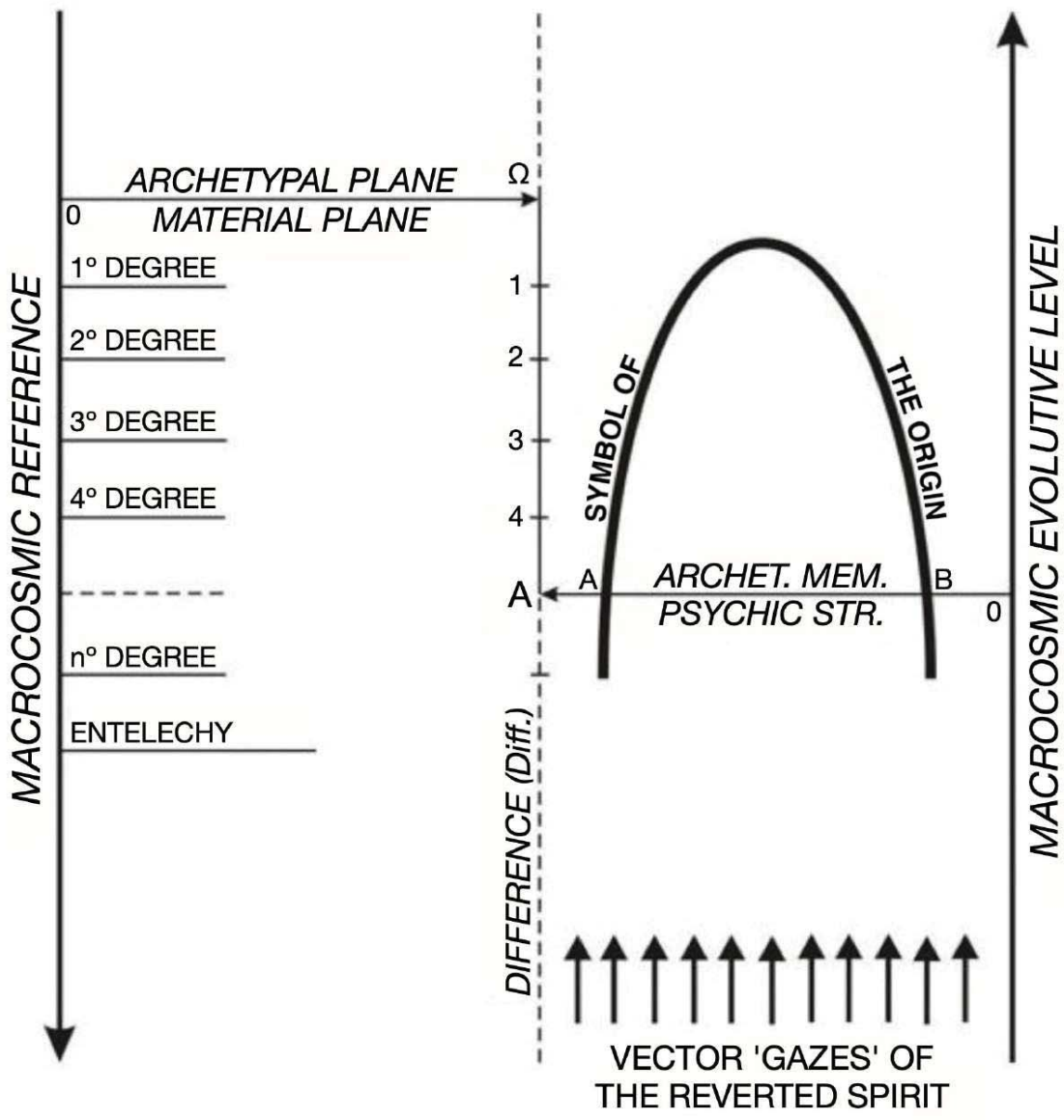

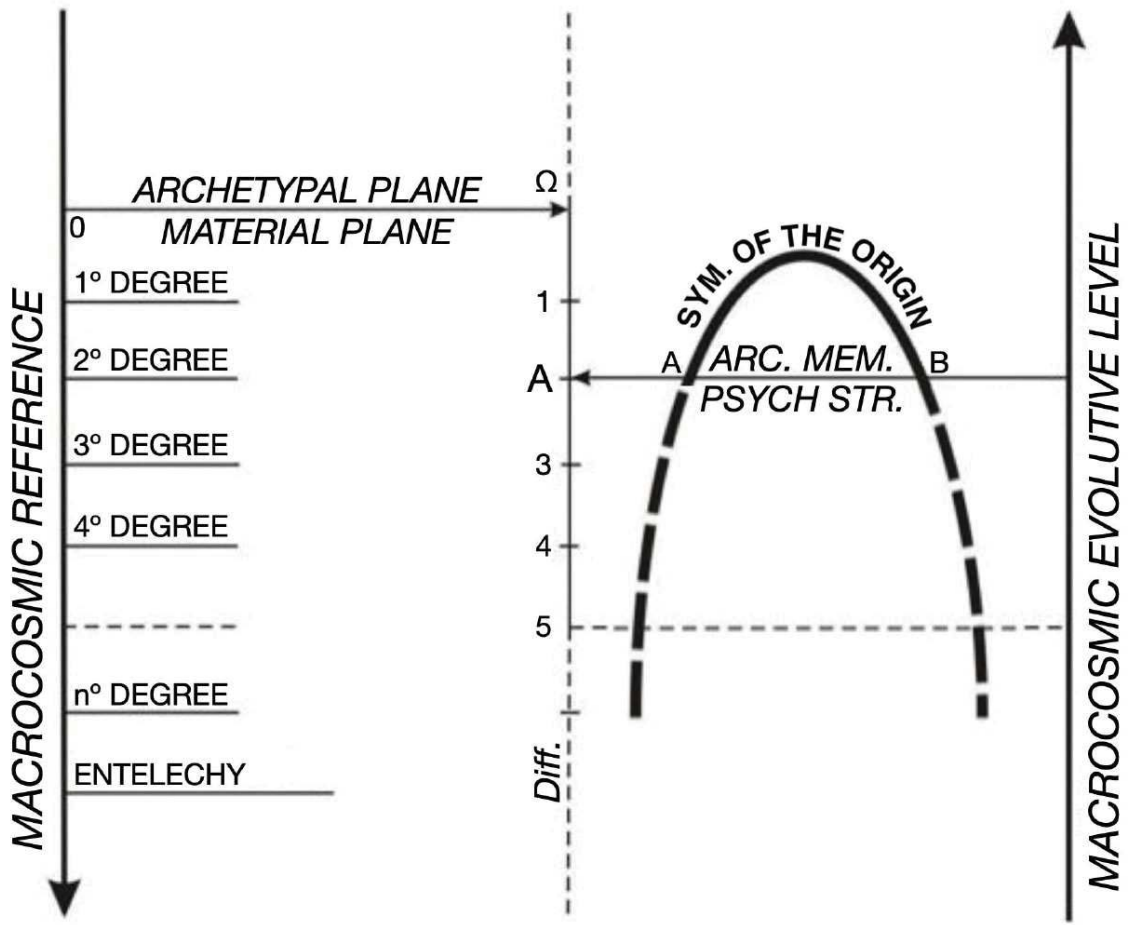

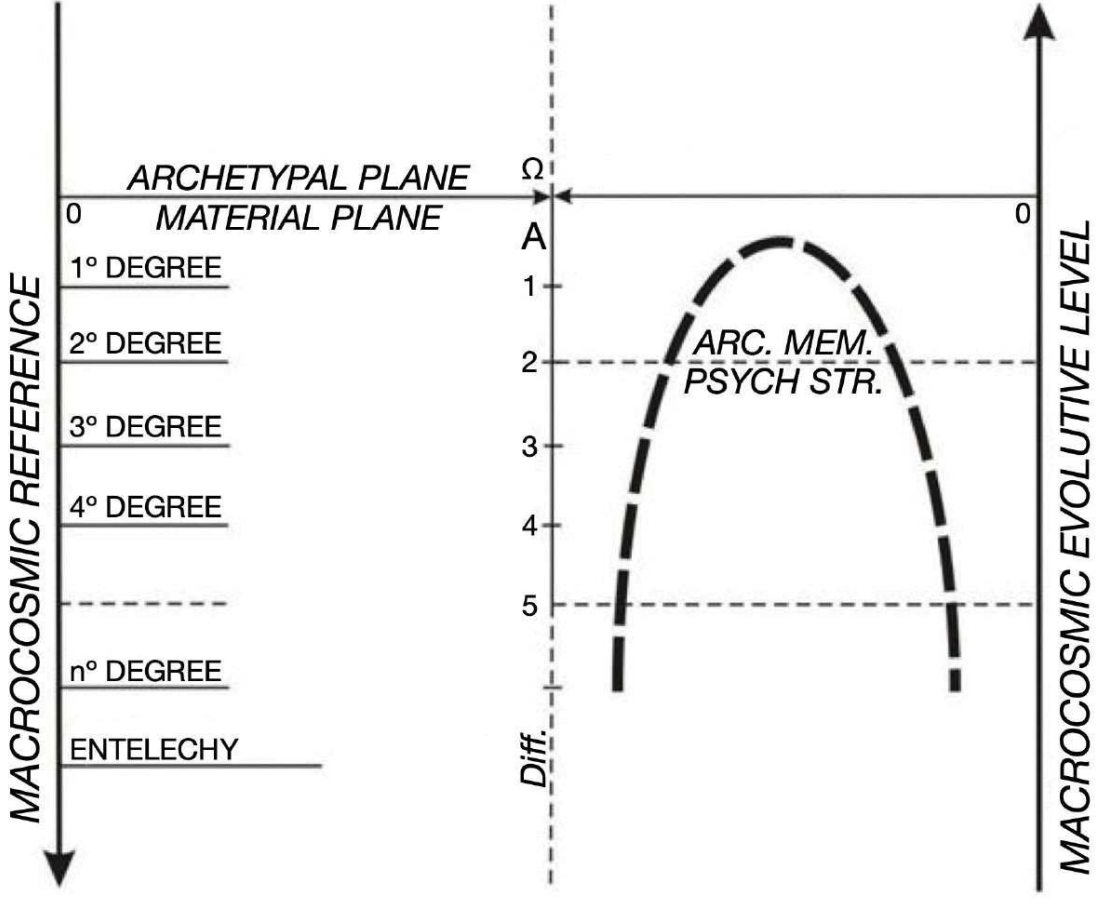

MANU ARCHETYPE

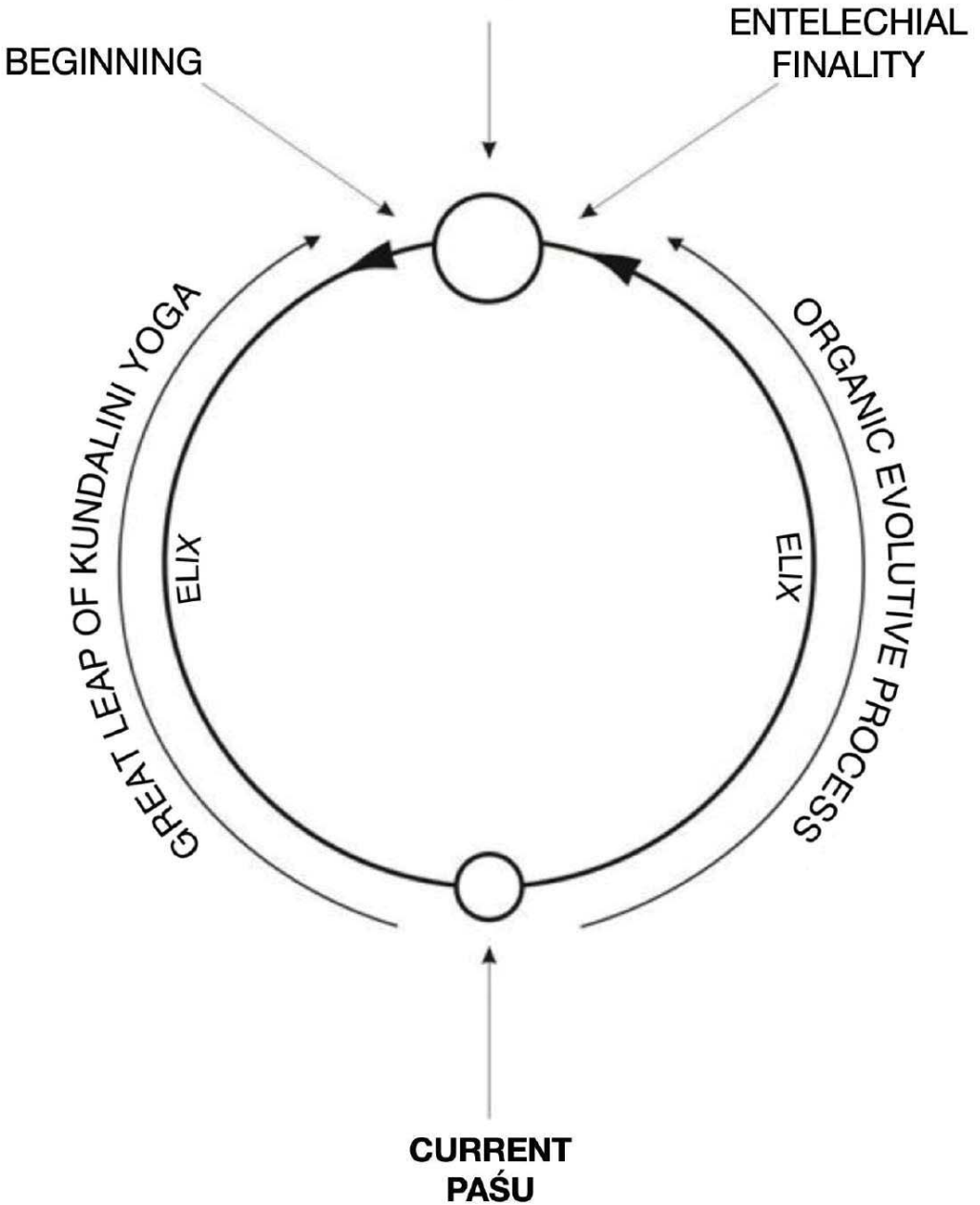

MANU ARCHETYPE

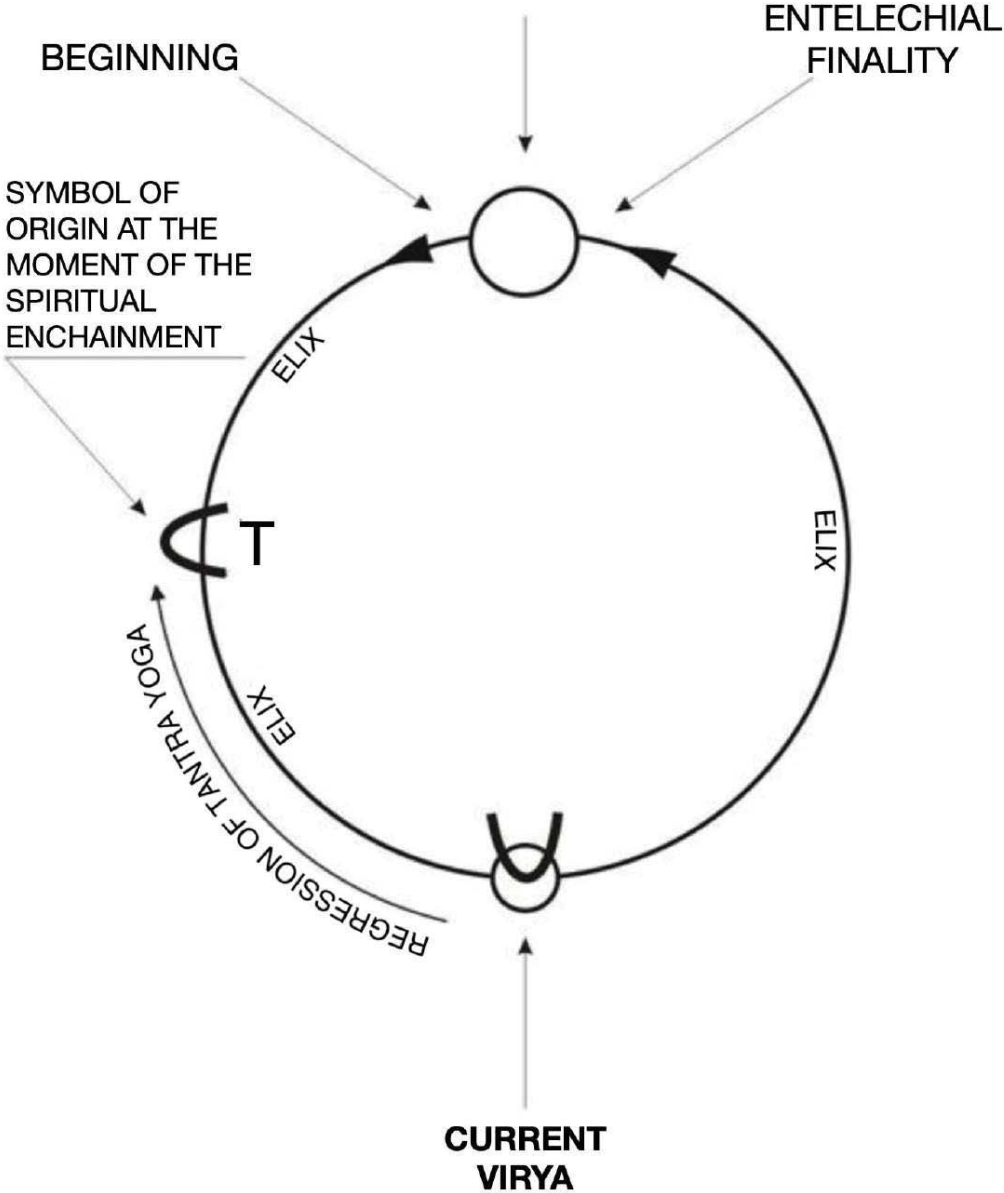

SYNOPTIC TABLE OF THE TWO MOVEMENTS THAT THE MICROCOSMIC OBJECTIVE OF THE PASU'S FINALITY REQUIRES

FIRST MOVEMENT: ESSENTIAL POSTULATE OF THE STRUCTURAL MODEL ONTIC SPHERE ≡ CYLINDRICAL BOND

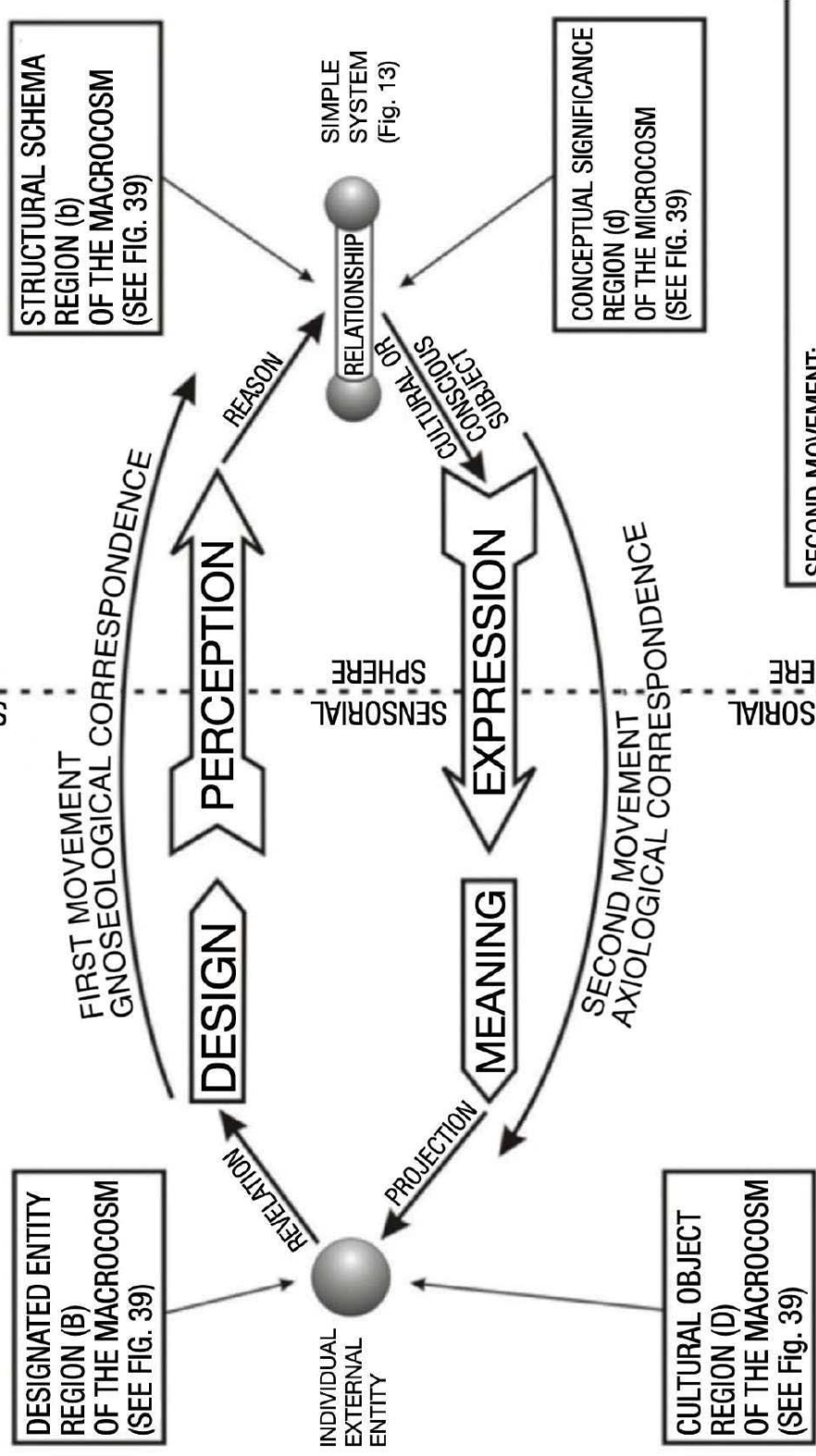

SECOND MOVEMENT: PATENTIAL POSTULATE OF THE STRUCTURAL MODEL HABITUAL SPHERE ≡ ESSENTIAL MATRIX

POTENTIAL POSTULATE OF THE STRUCTURAL MODEL: HABITUAL CONCEPT \equiv ESSENTIAL MATRIX

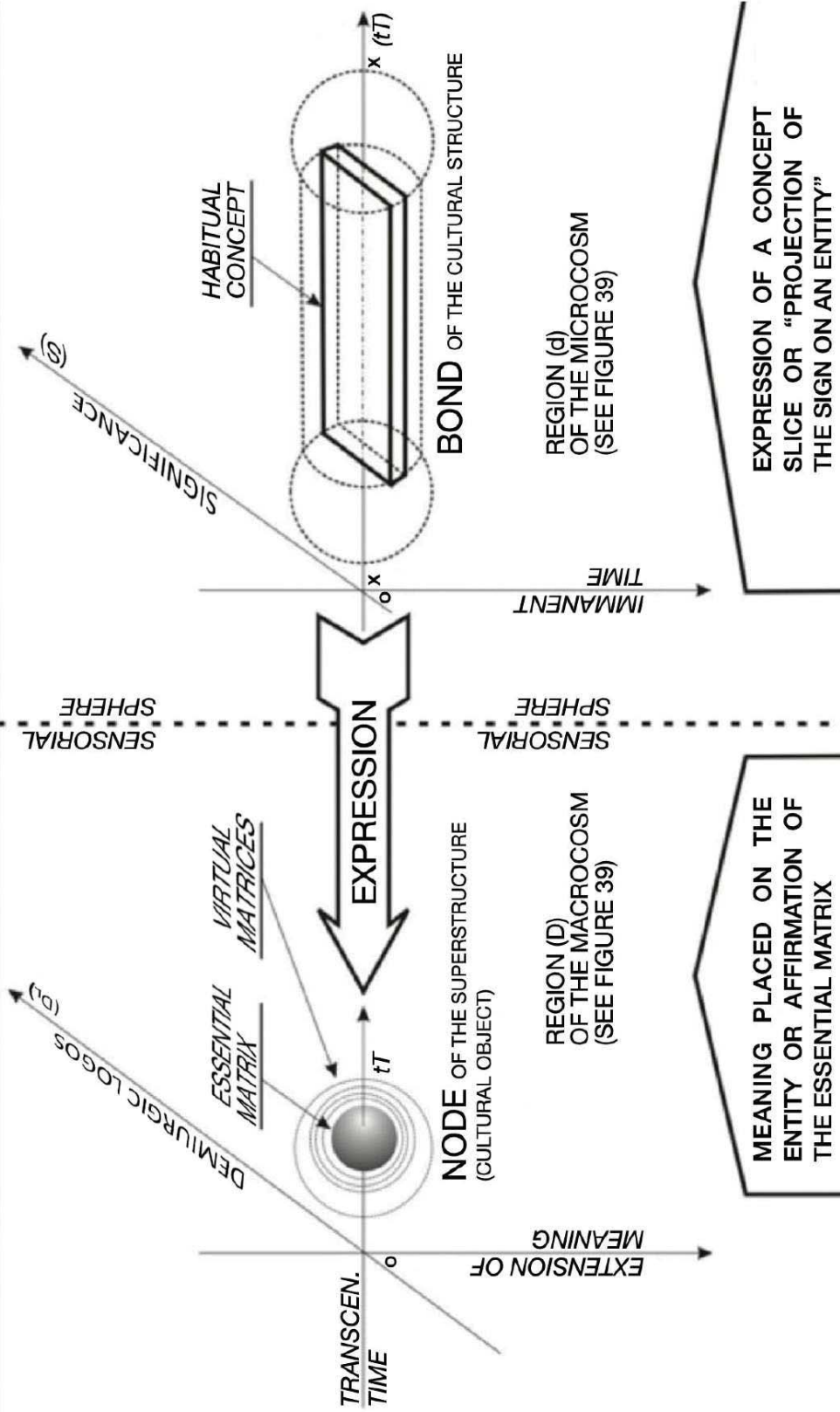

METHODOLOGICAL RELATIONSHIP BETWEEN SUPERSTRUCTURE AND CULTURAL STRUCTURE MODELS

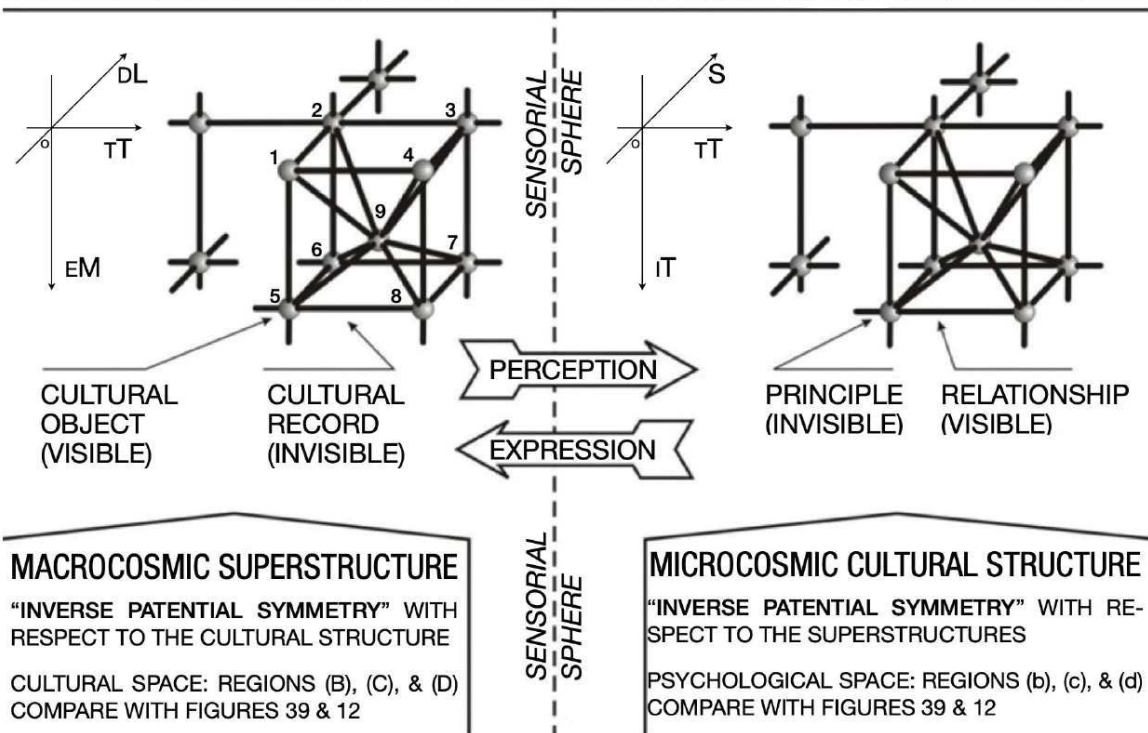

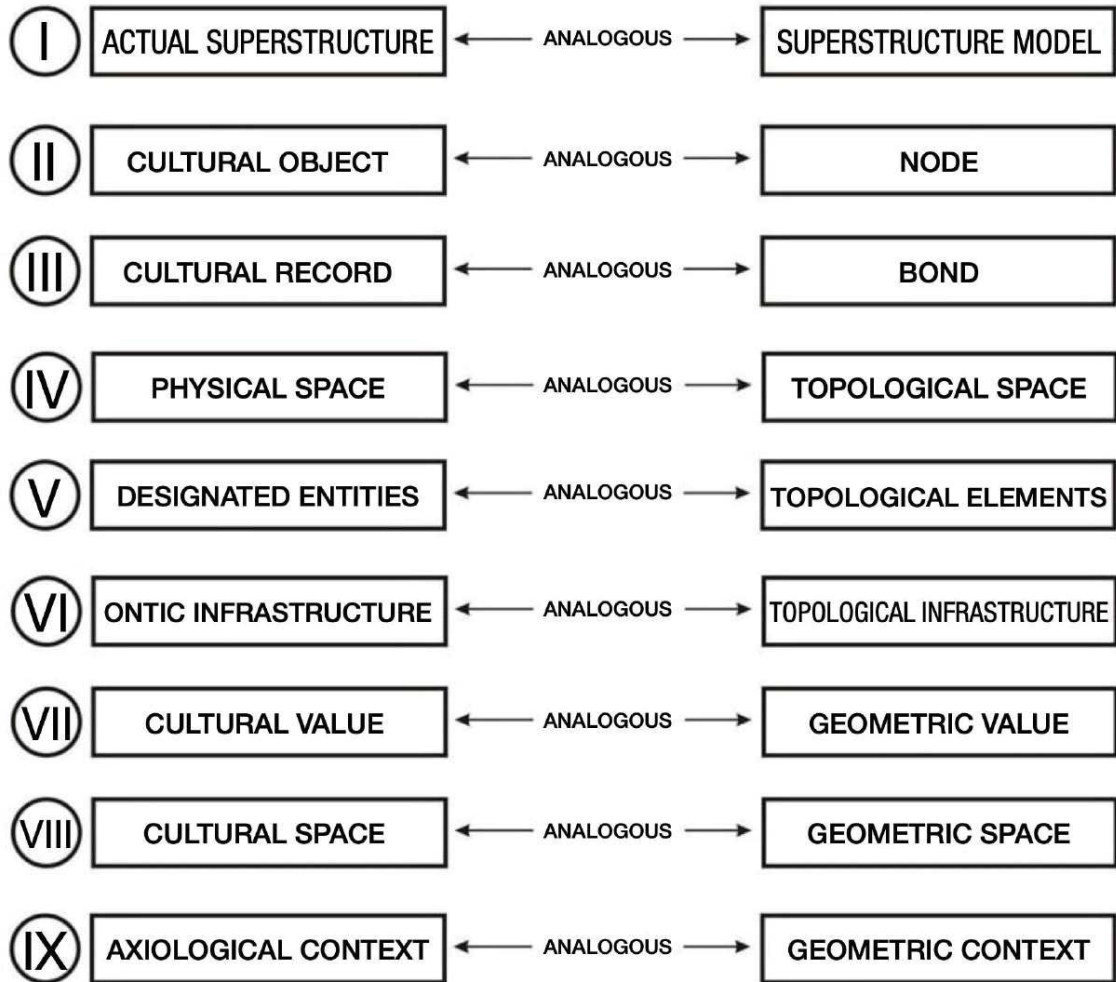

**SIMPLE SYSTEM OF THE
CULTURAL STRUCTURE MODEL**
(SEE FIG. 13)

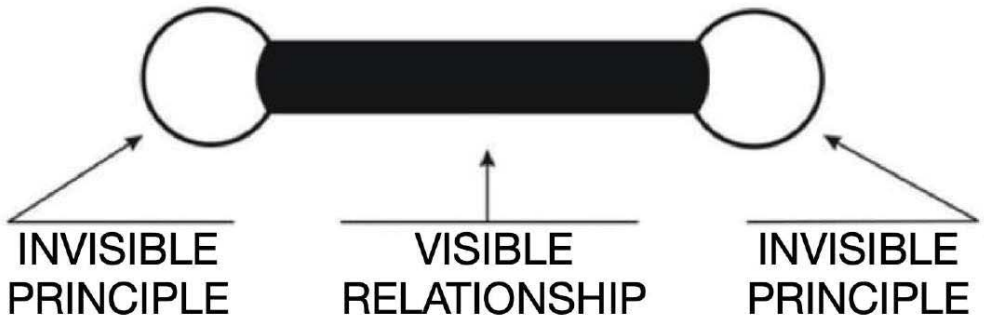

**ACTUAL SYSTEM OF THE
SUPERSTRUCTURE MODEL**
(SEE FIG. 75)

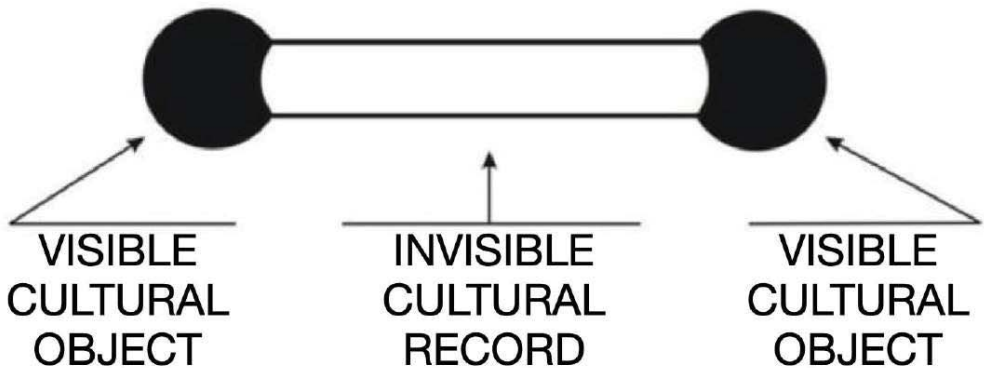

“ACTUAL SYSTEM” OF THE SUPERSTRUCTURE MODEL

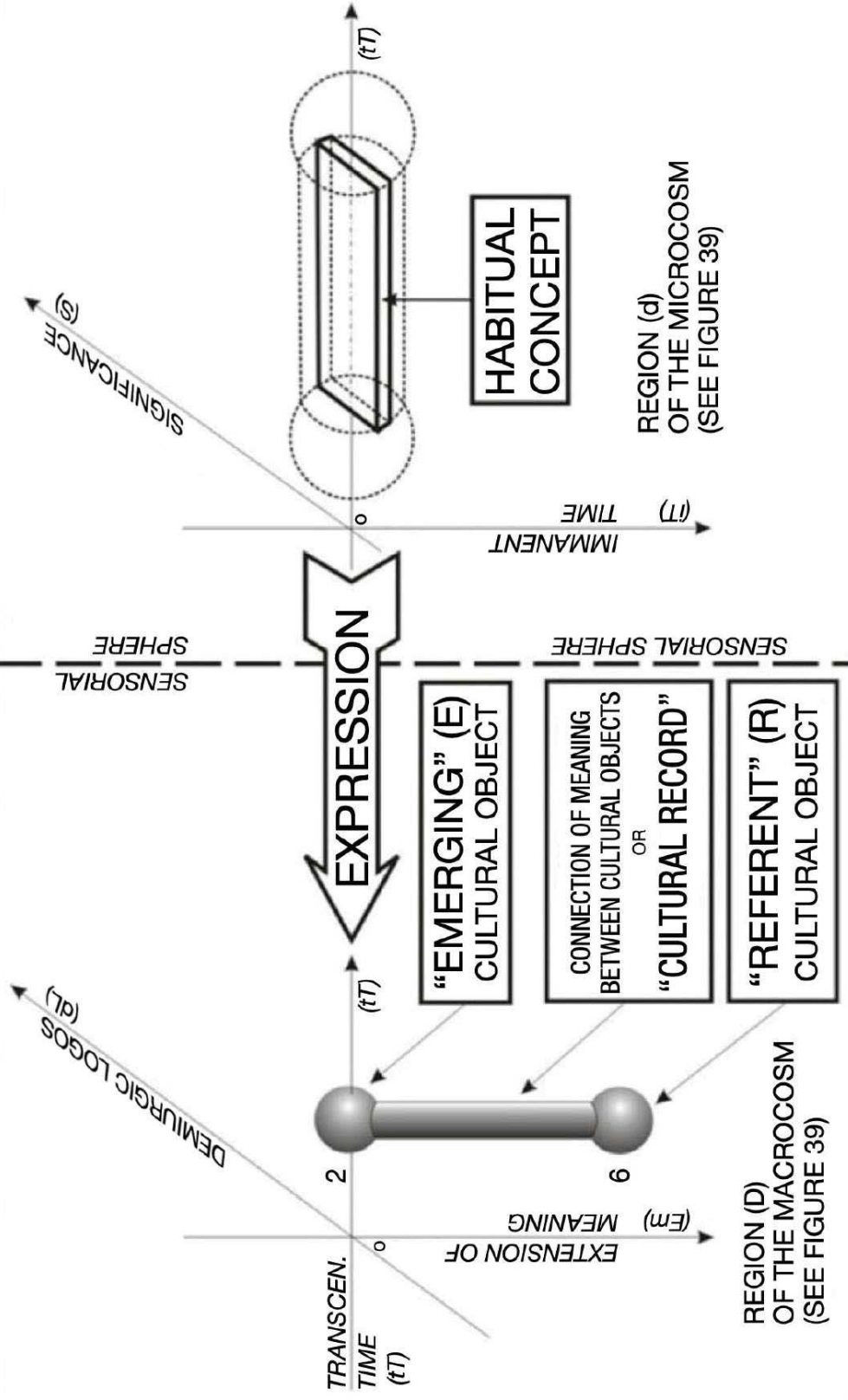

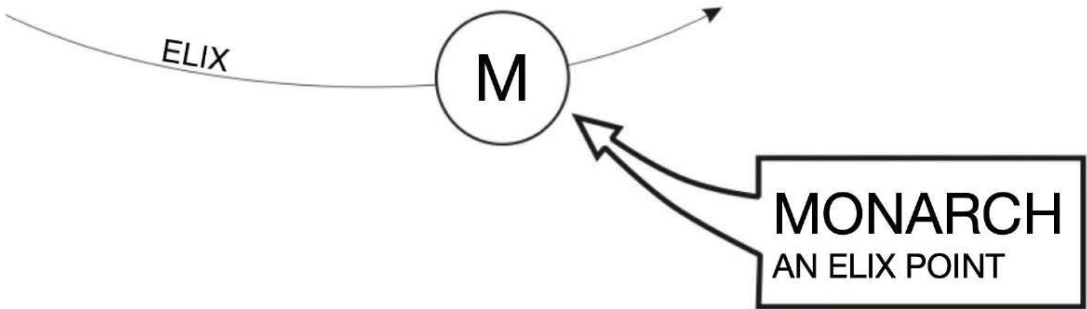
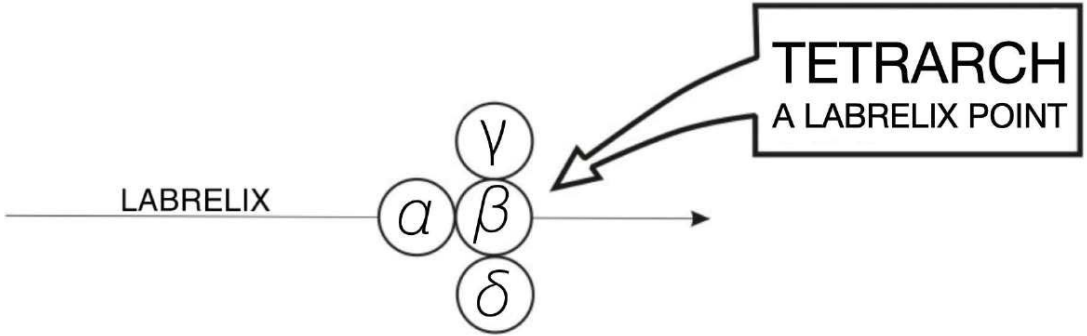

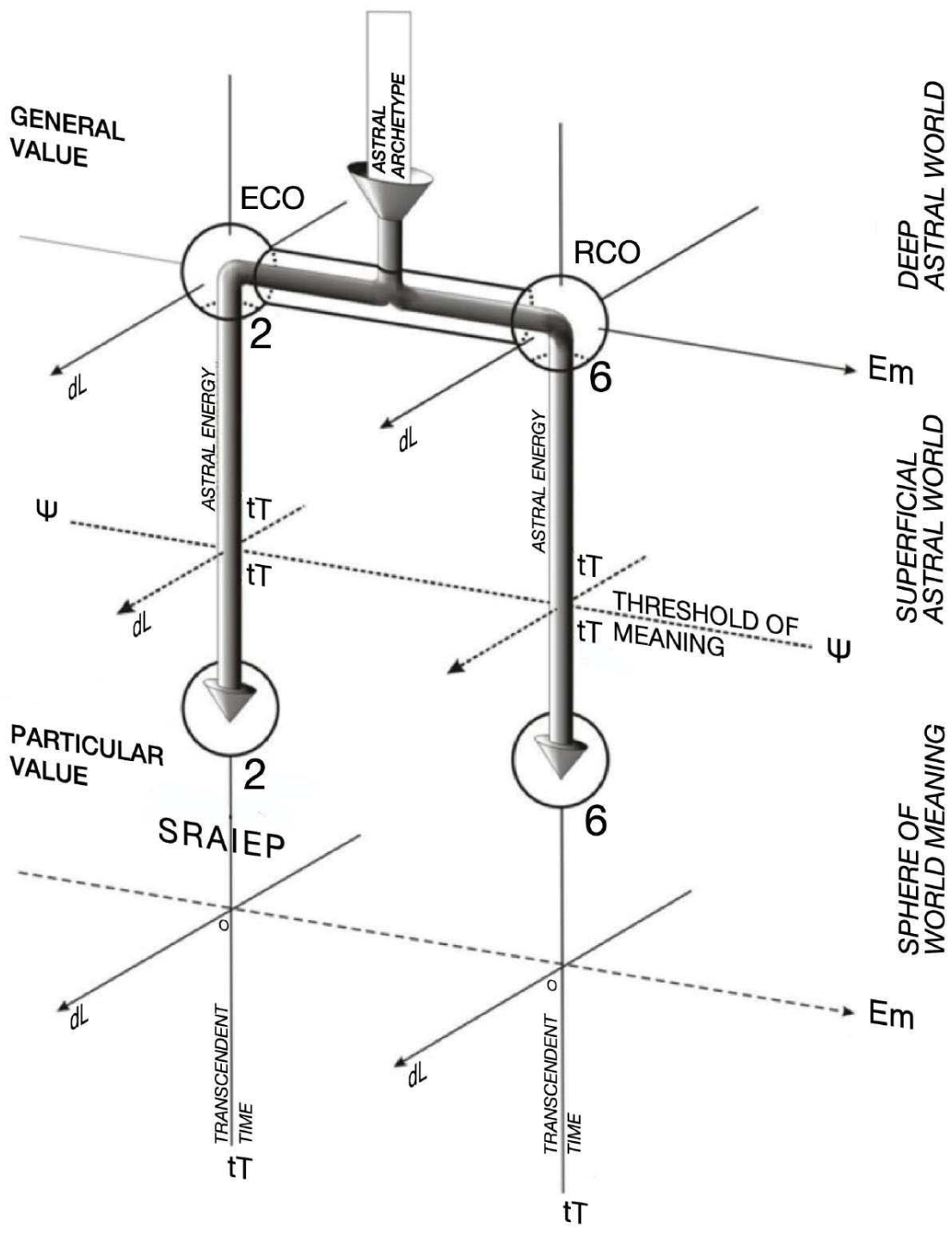

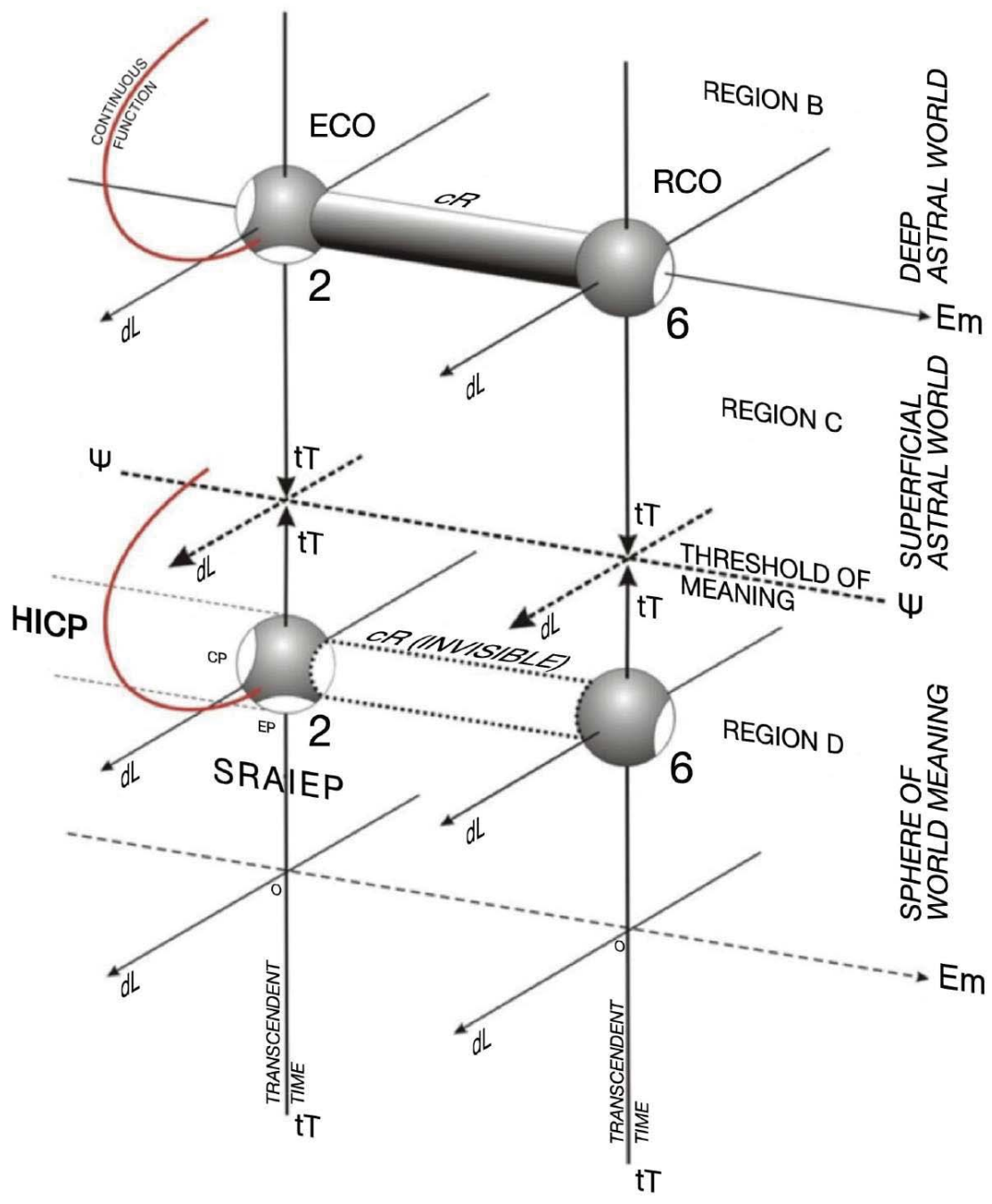

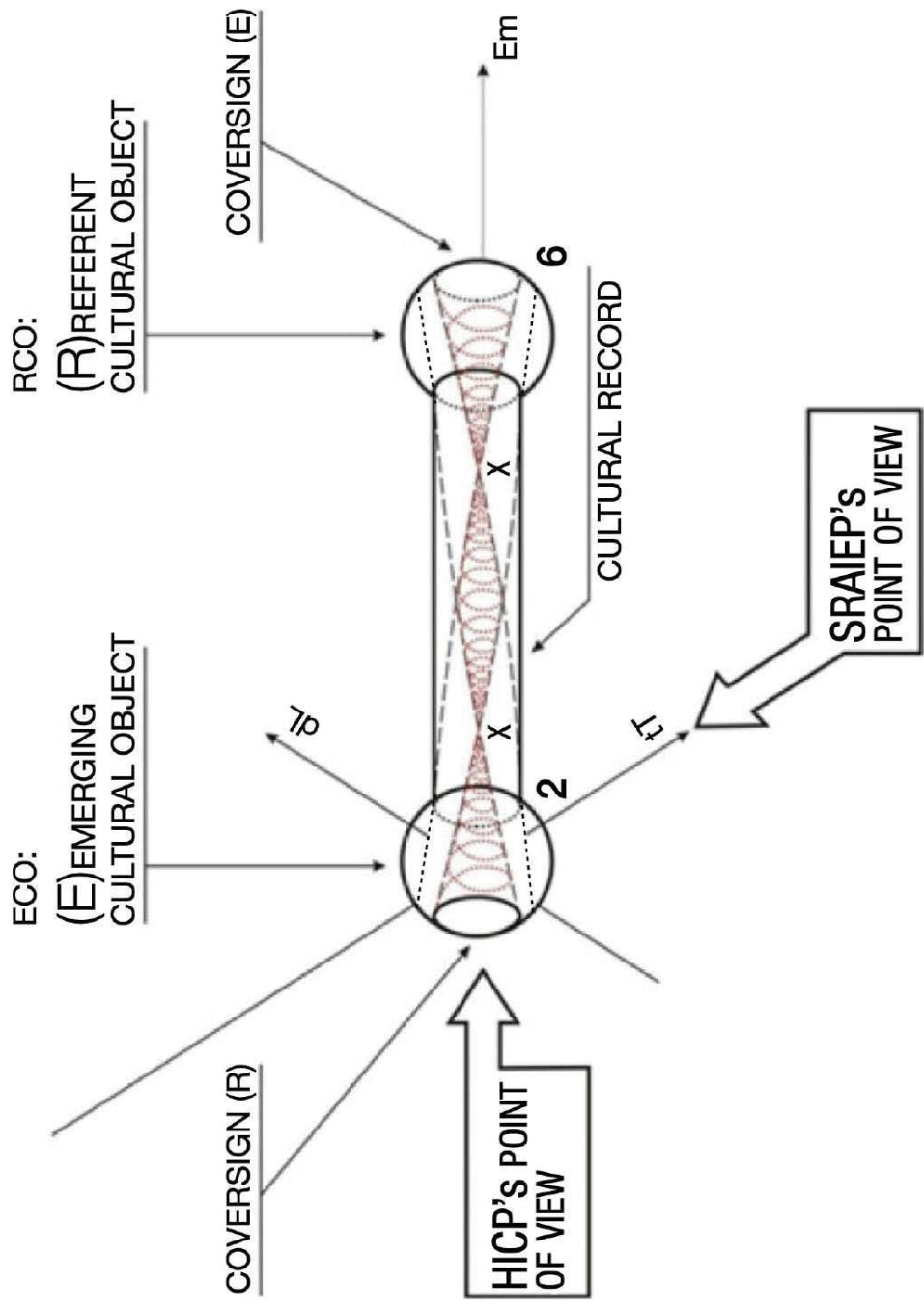

EXPLORATION OF AN ACTUAL SYSTEM WITH THE FACULTY OF ANAMORPHOSIS OF THE HYPERBOREAN INITIATE OR TIRODAL KNIGHT: HICP

A

B

DIRECTION OF
THE TRAVELER →

(X)

DOOR
PHASE: ENTRY
(CAUSE)

DOOR
PHASE: EXIT
(EFFECT)



A

B

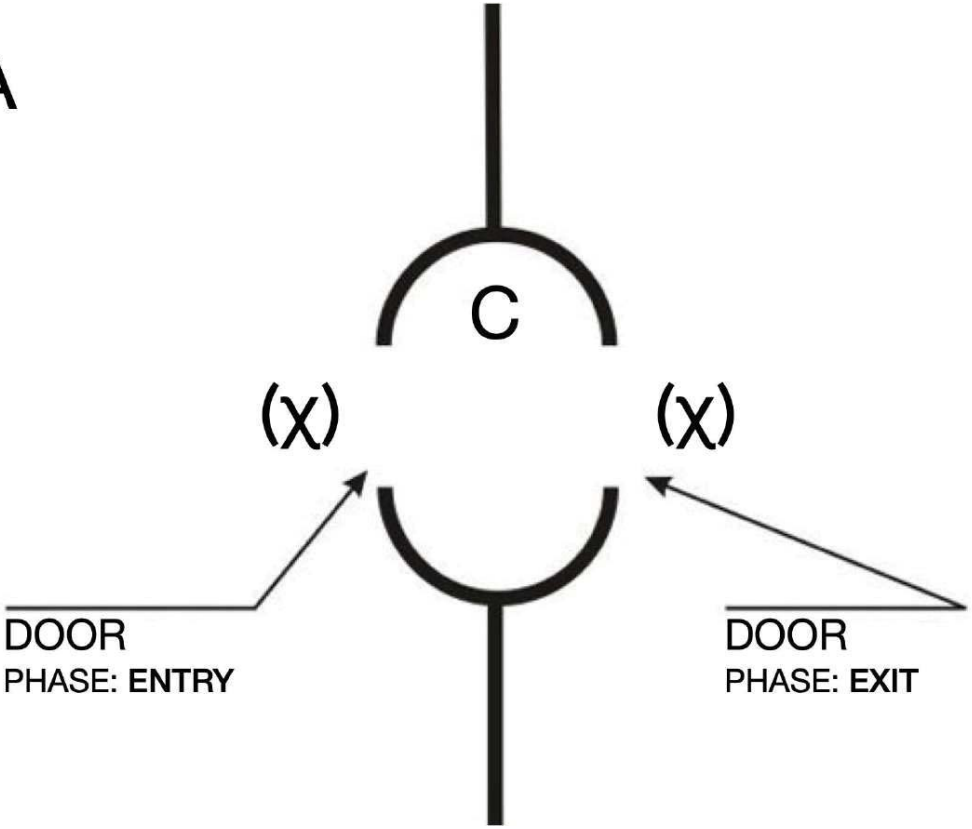

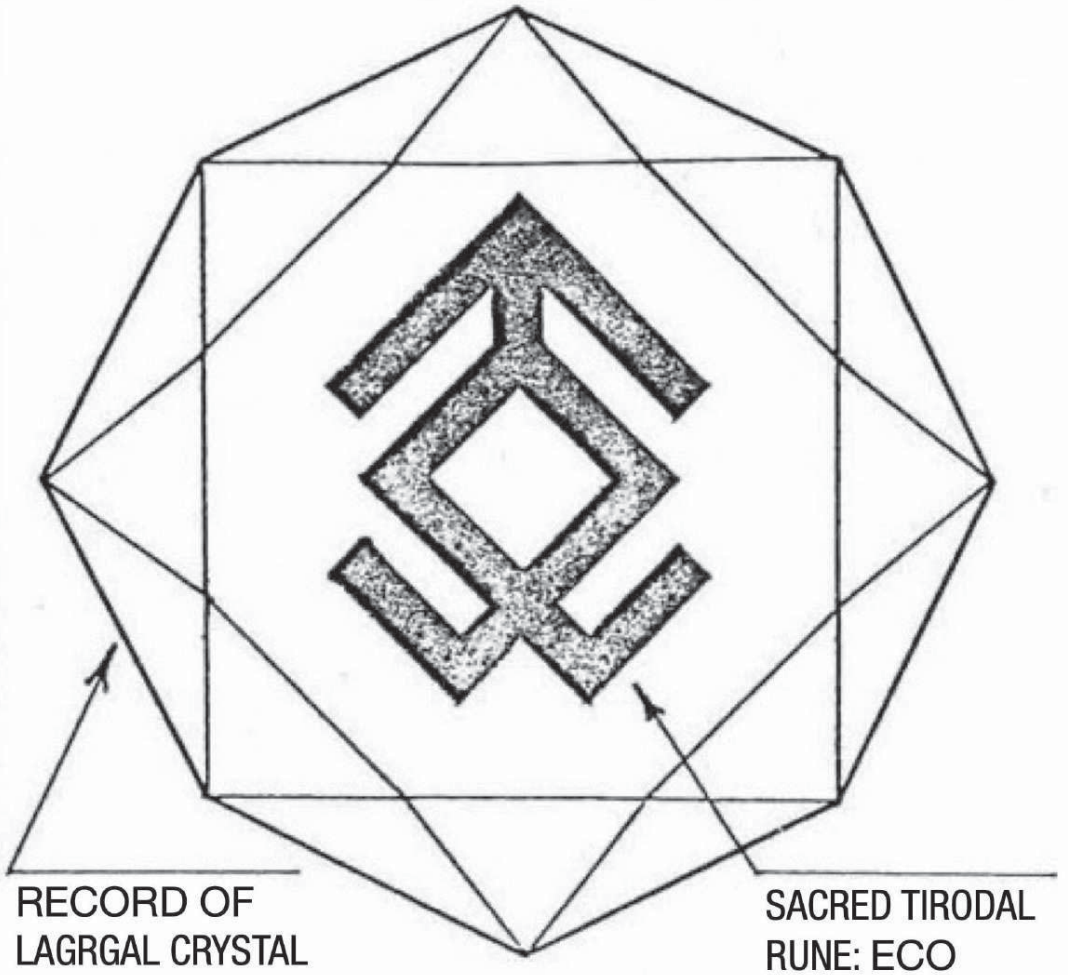

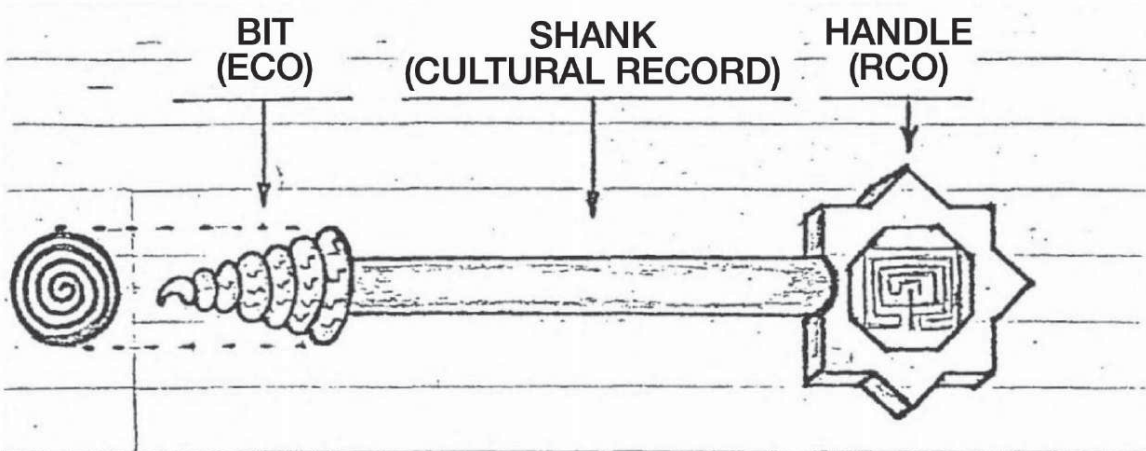

**ALLEGORICAL DRAWING OF THE
KALACHAKRA KEY**

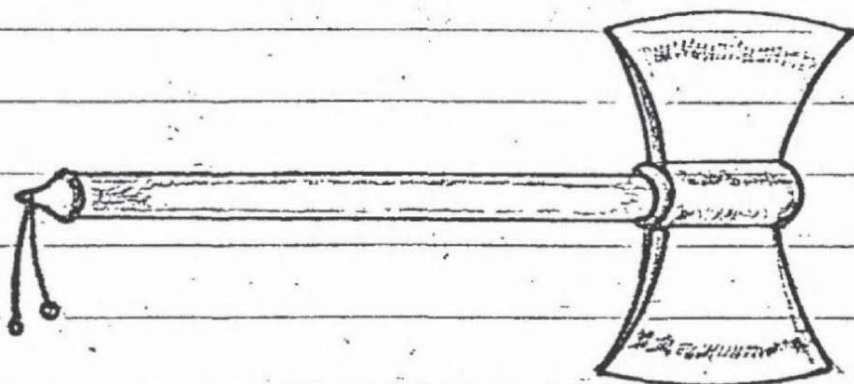

THE LABRYS OF FREYA-KALY

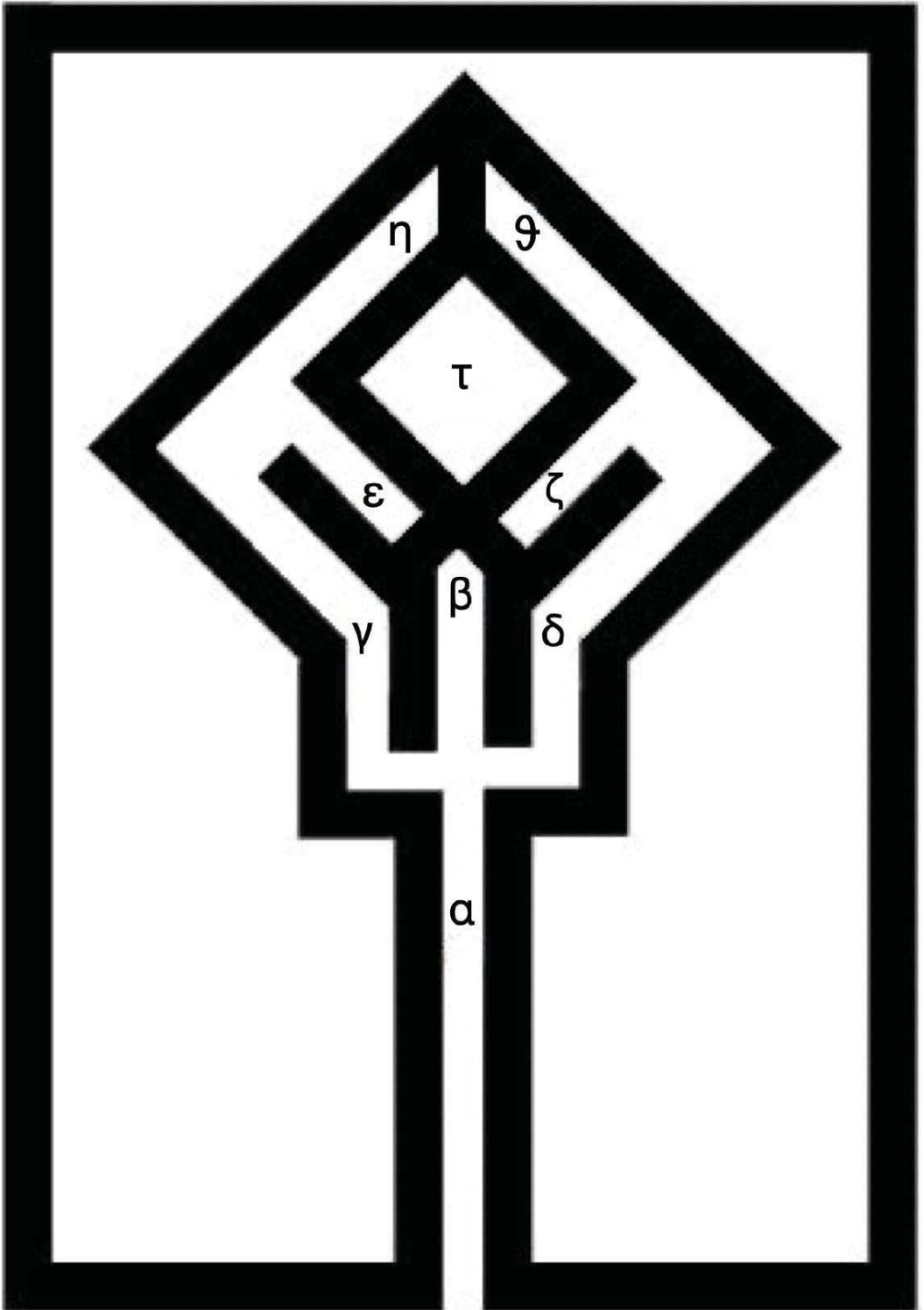

VALLO OBSESSO
(ODAL ARCHEMON)

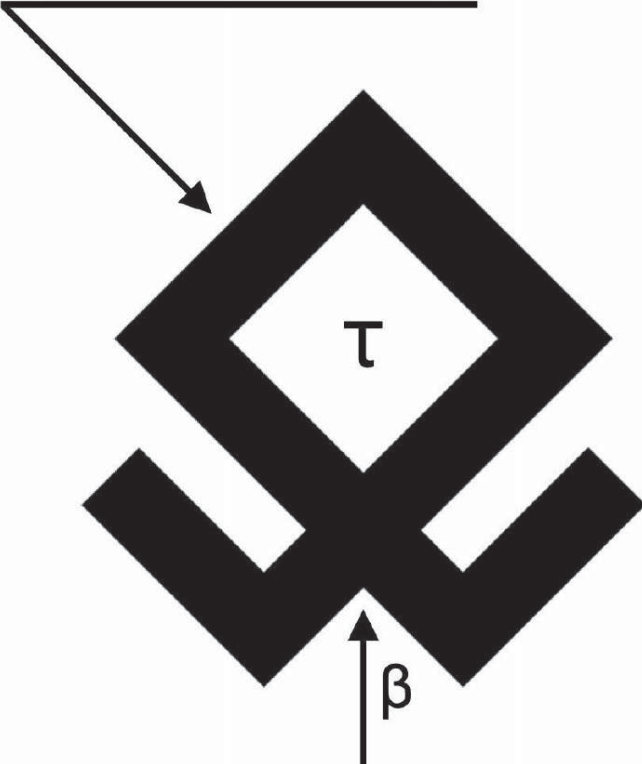

FENESTRA INFERNALIS

τ : OPPIDUM
(PLAZA)

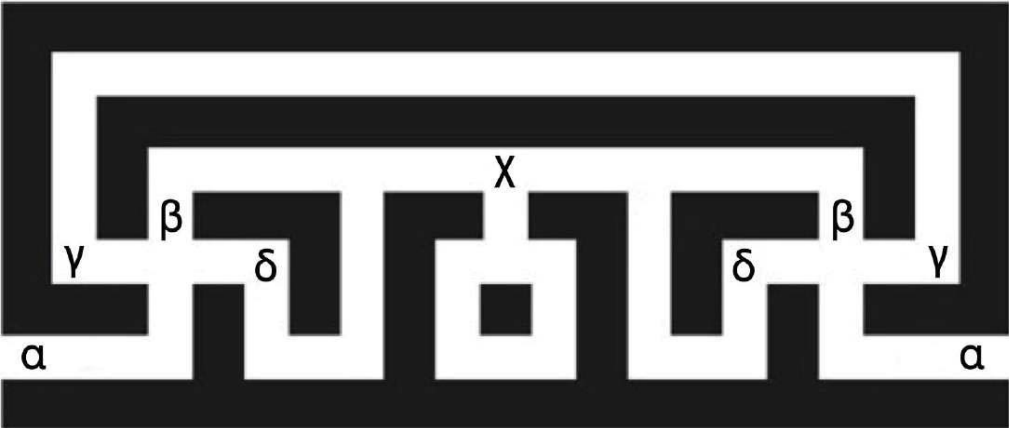

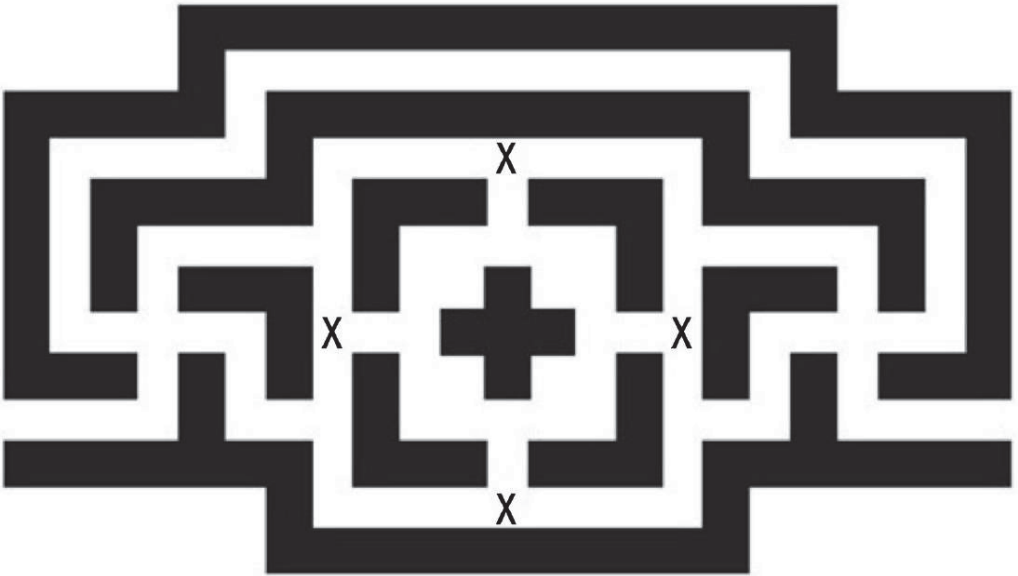

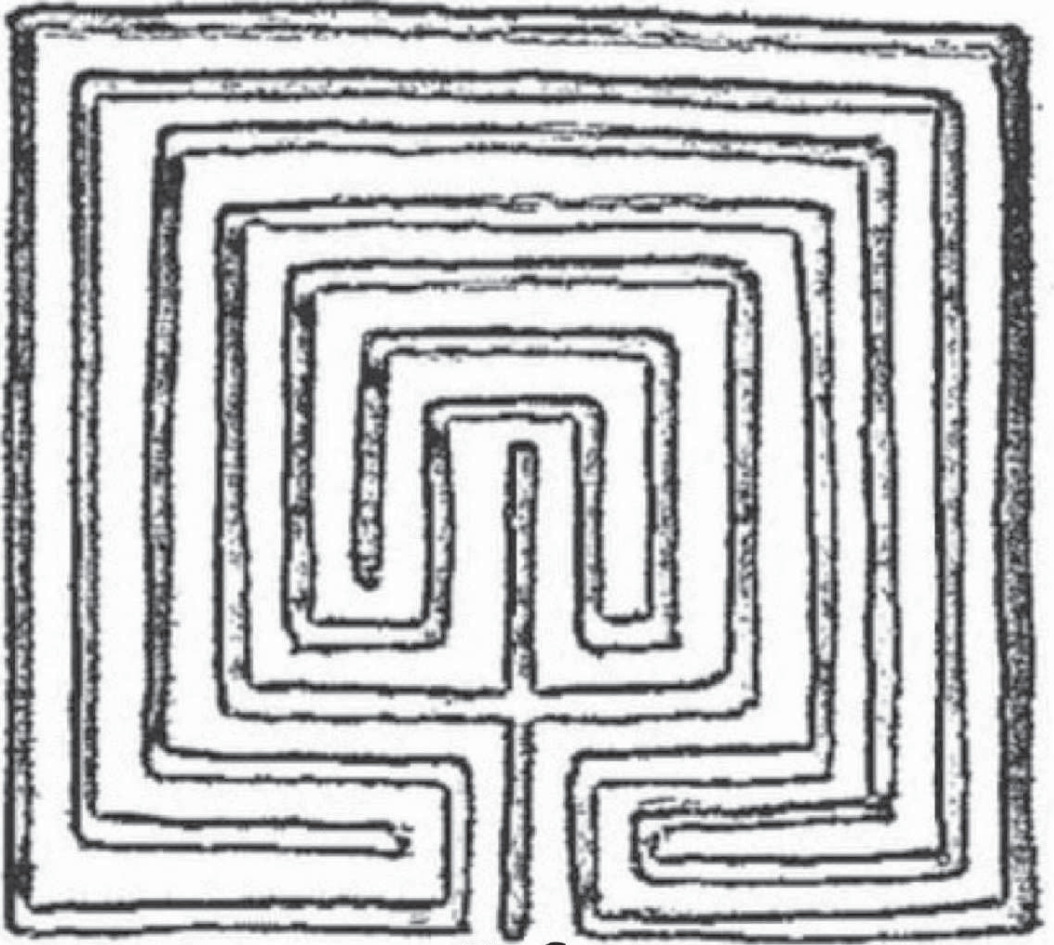

$\gamma \delta$

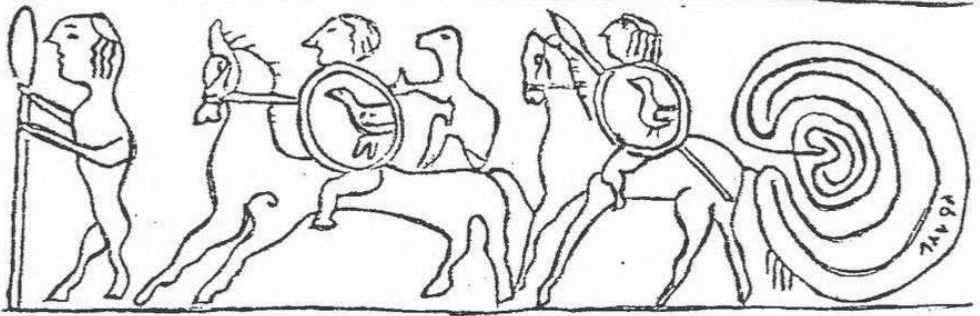

744

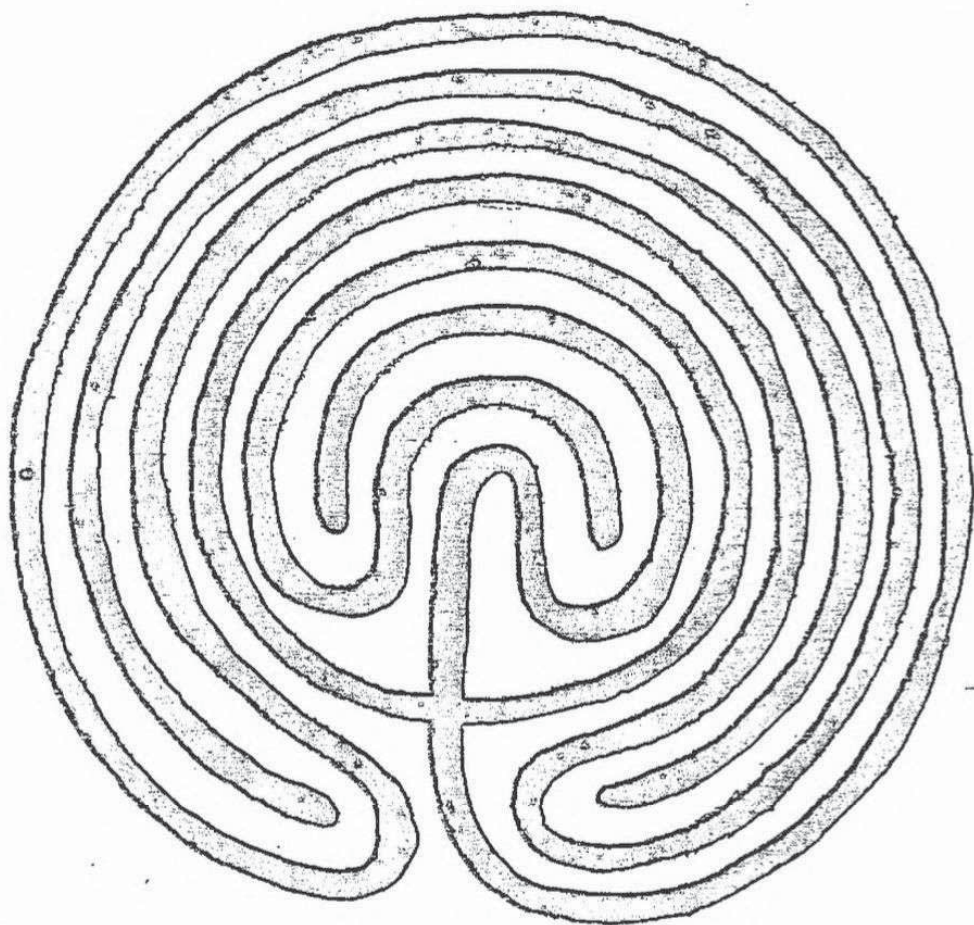

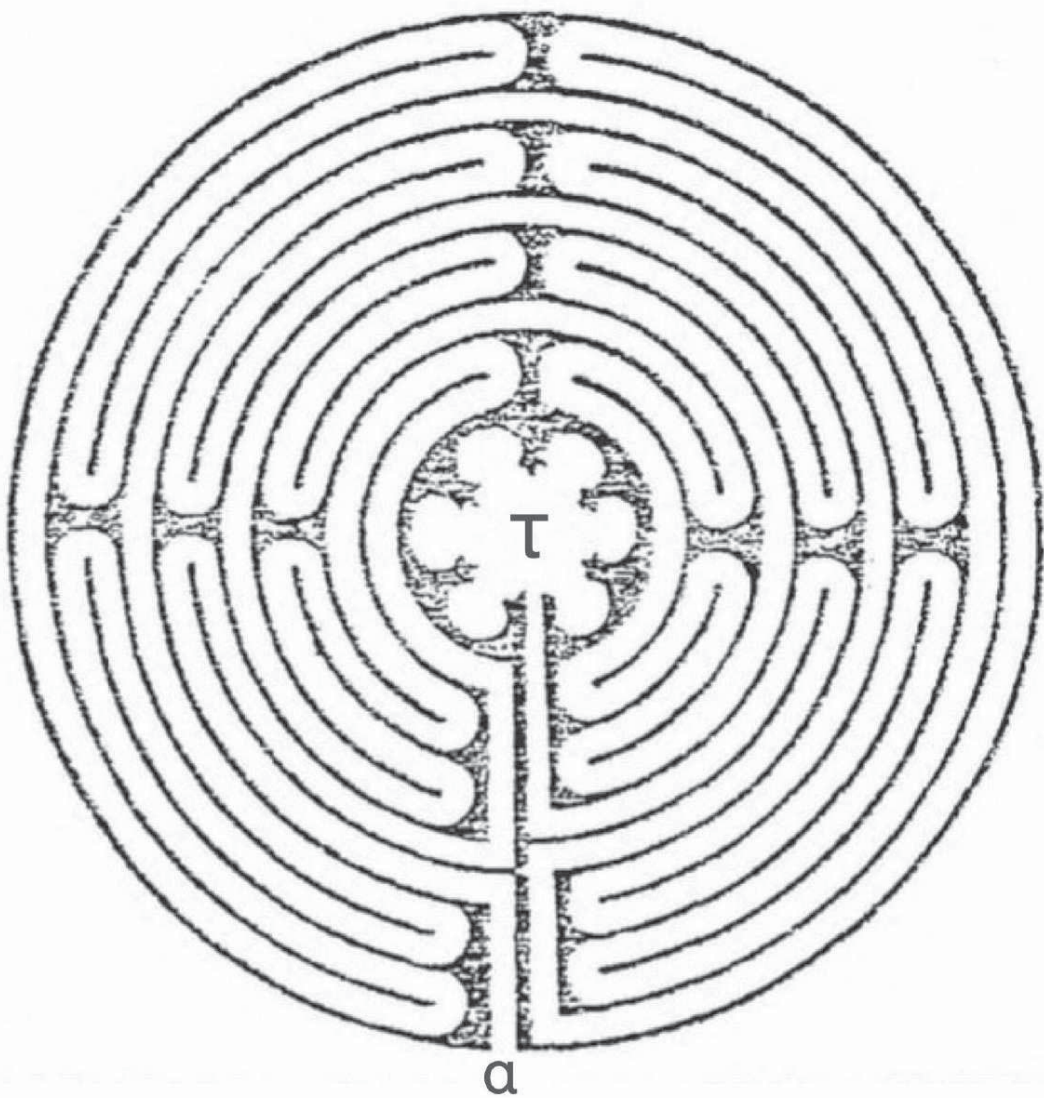

THE THREE TYPES OF LOST VIRYA ACCORDING TO NOOLOGICAL ETHICS

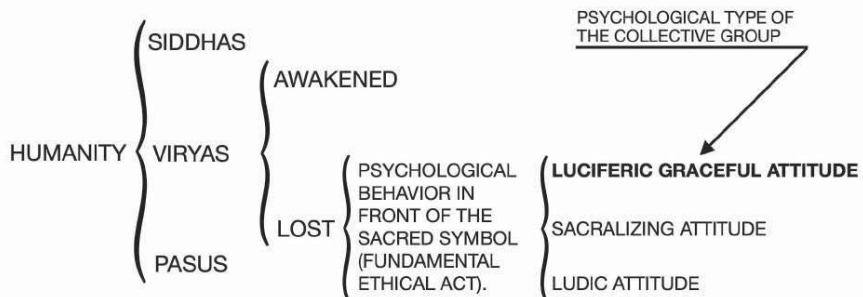

CORRESPONDENCE BETWEEN ABERRANT TYPOLOGY AND INDO-ARYAN TYPOLOGY

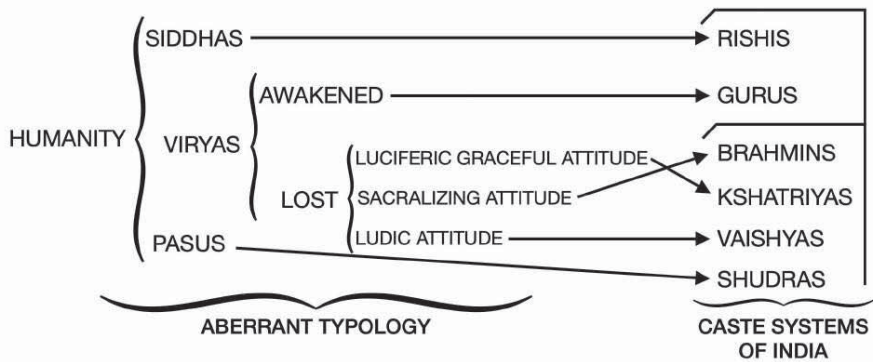

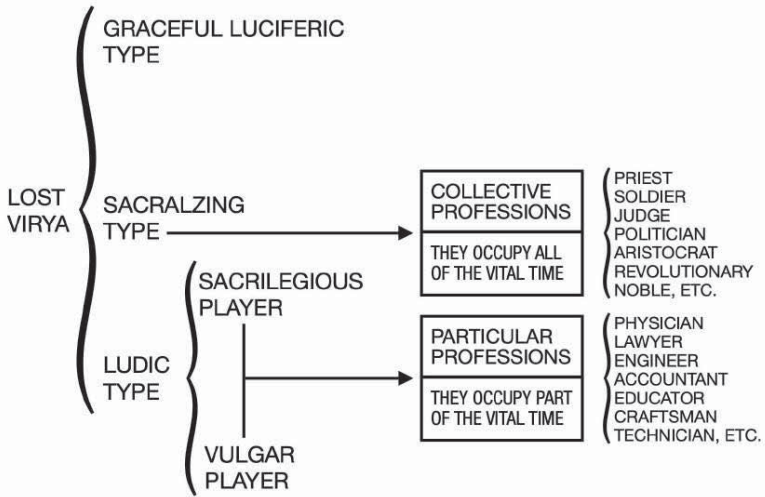

PARTICULAR VALUE OF AN EMERGING (E) CULTURAL OBJECT "ACTUAL SYSTEM" OF THE SUPERSTRUCTURE

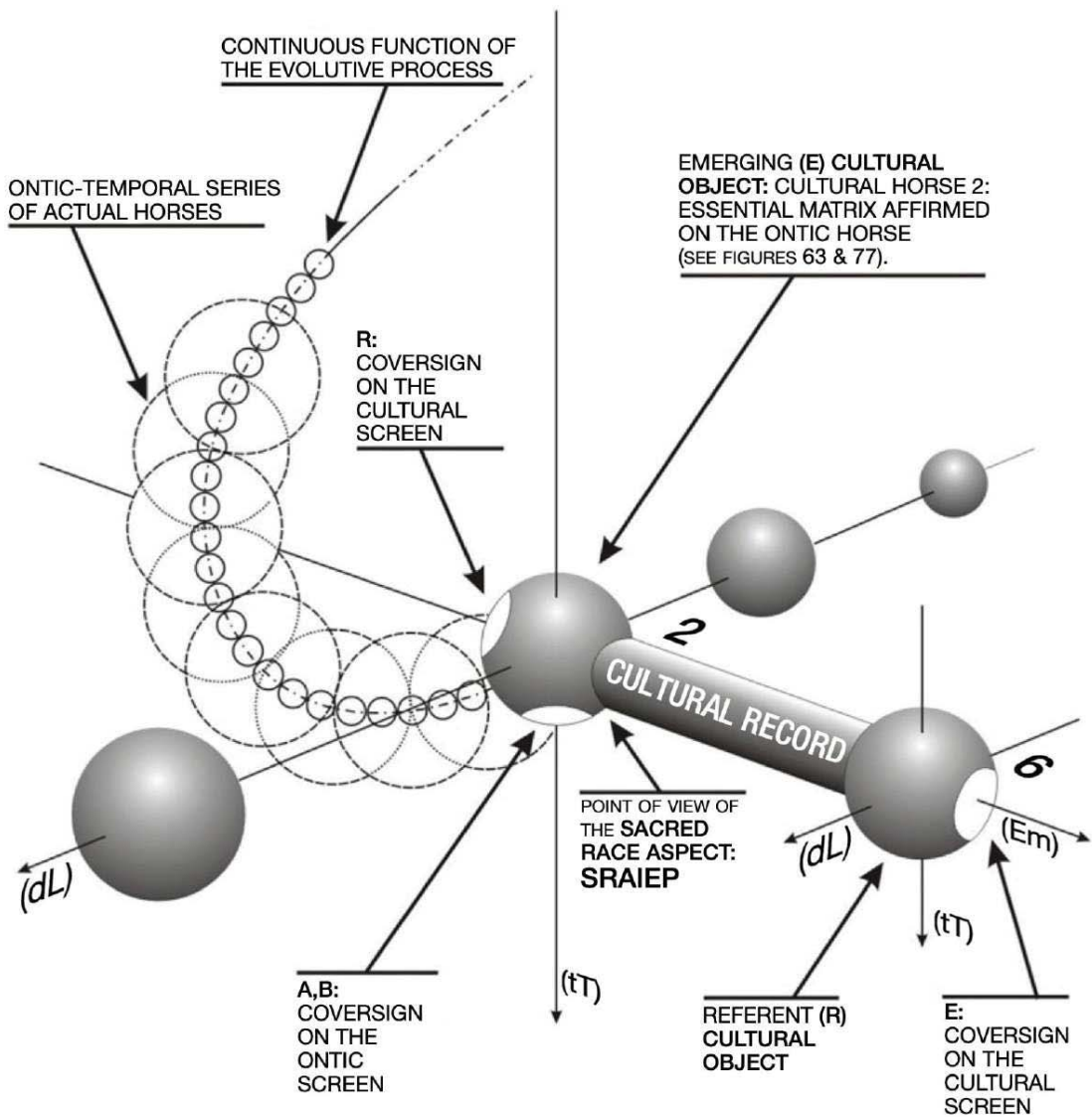

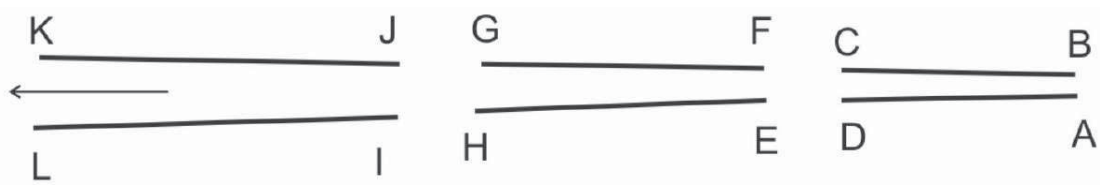

K J

L ZUTANO I

G F

H MONTANO E

C MENGANO B

D A

K _____ J

MENGANO

D _____ A

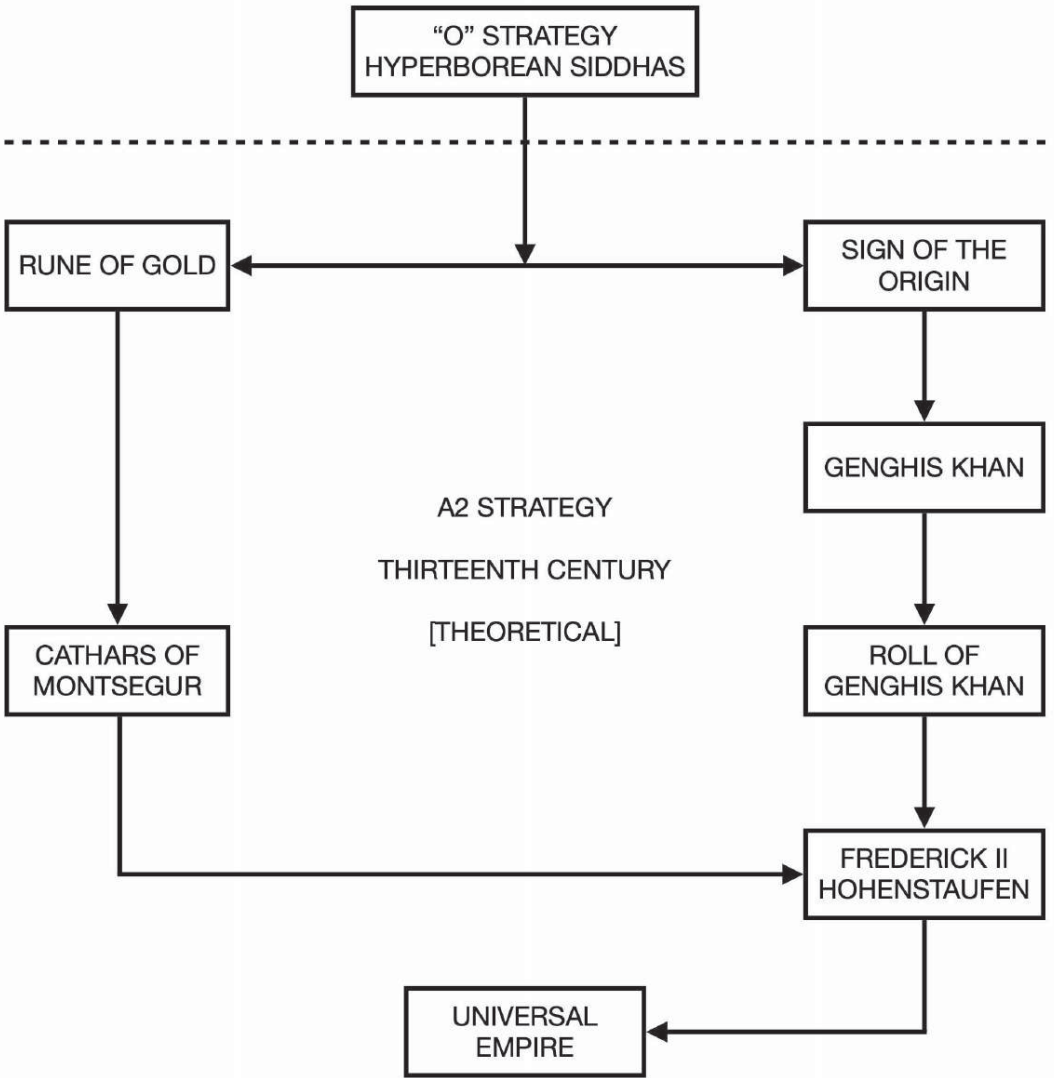

“This is how historical events should have unfolded.”

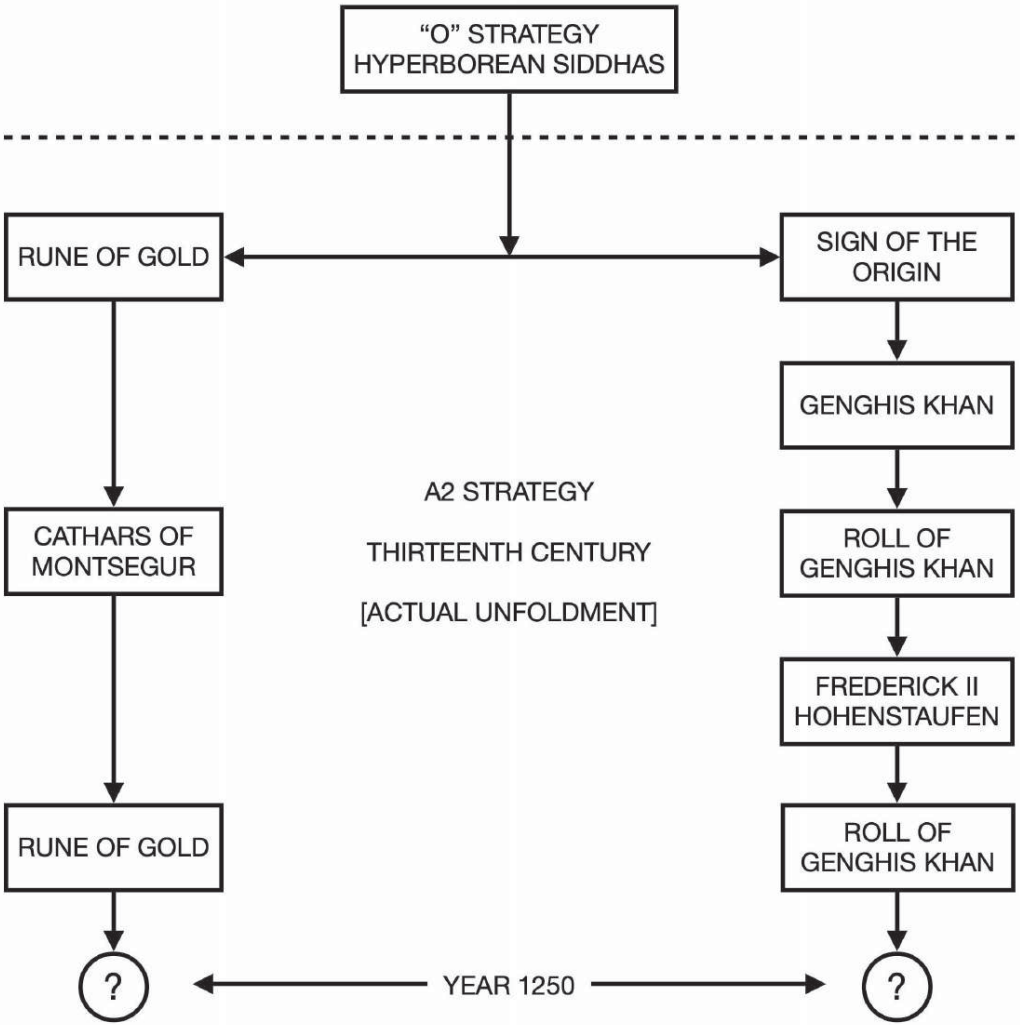

“Instead, historical events happened like this.”

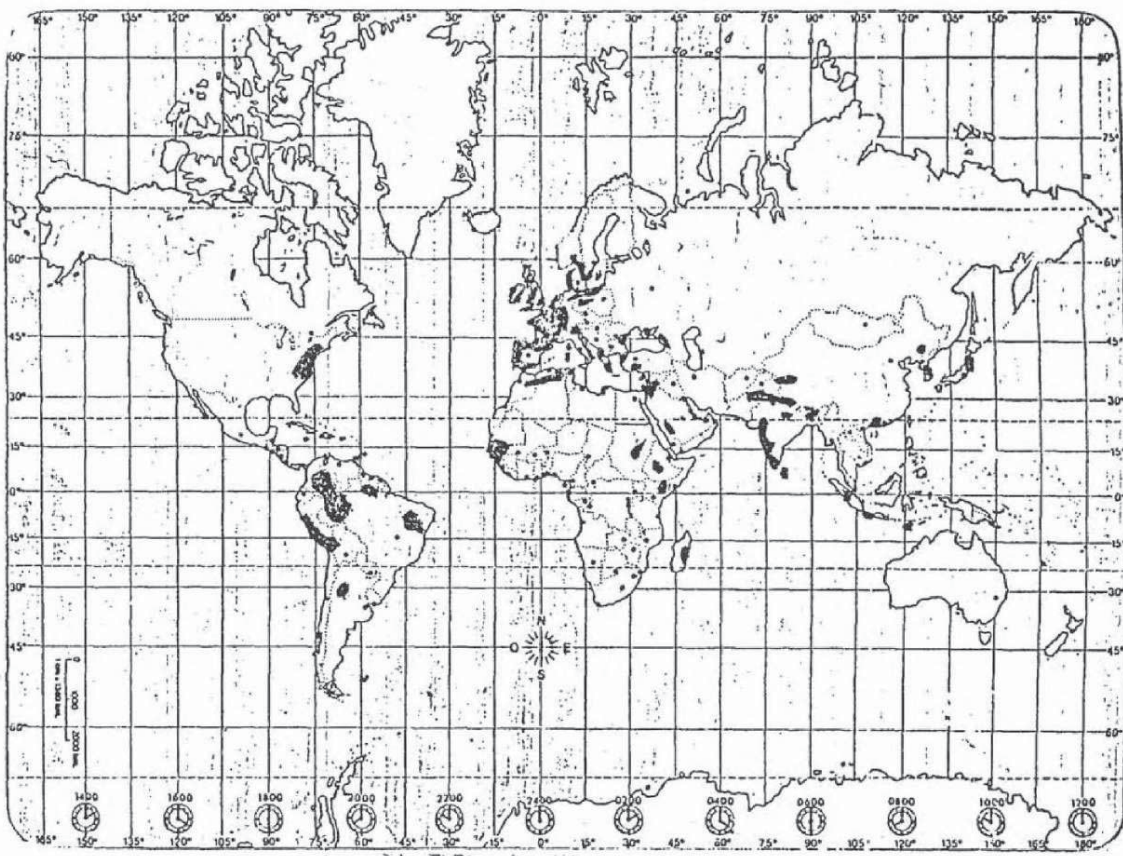

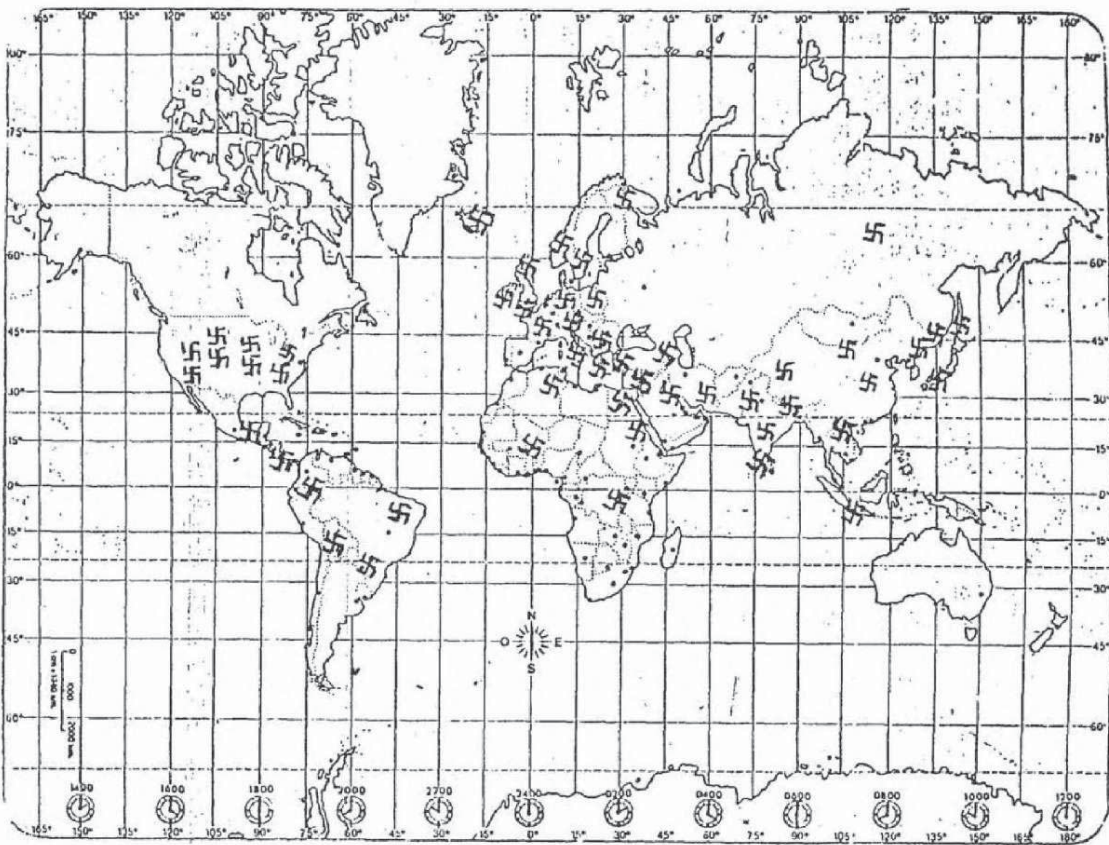

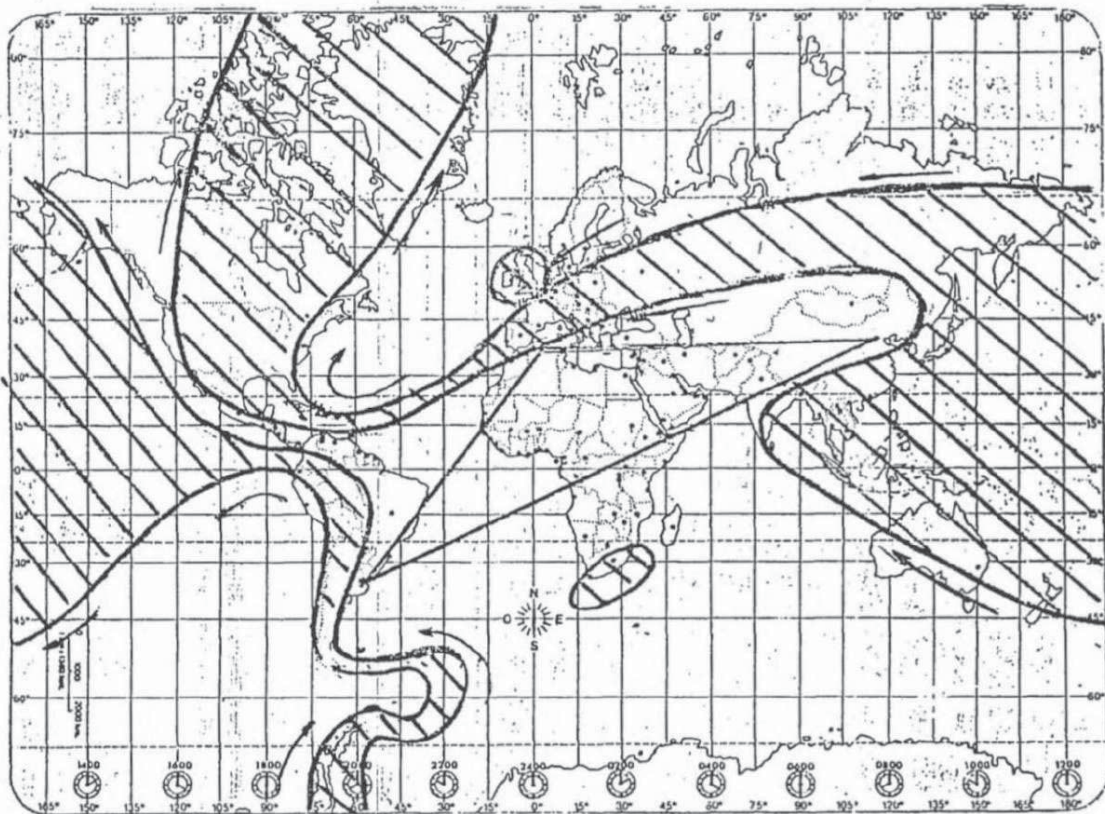

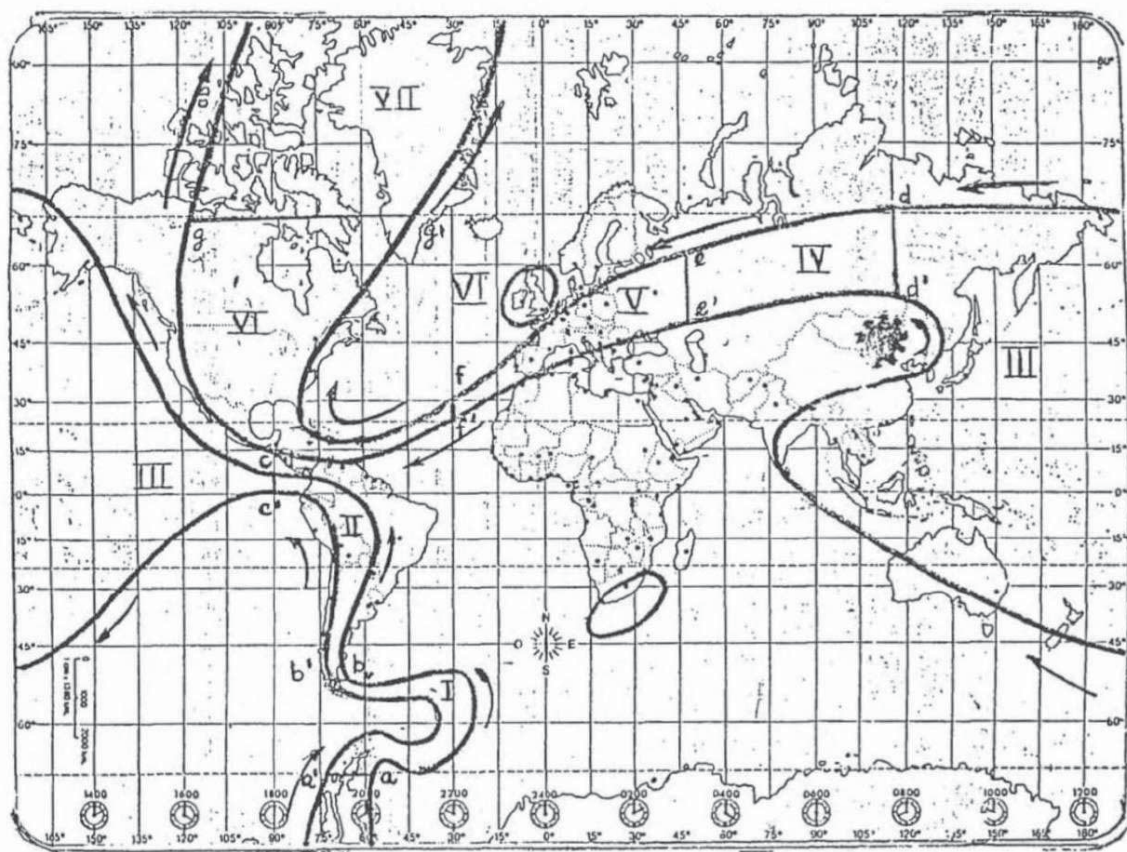

SCHEMATIC VIEW OF THE WHOLE OSSEOUS LABYRINTH - RIGHT SIDE

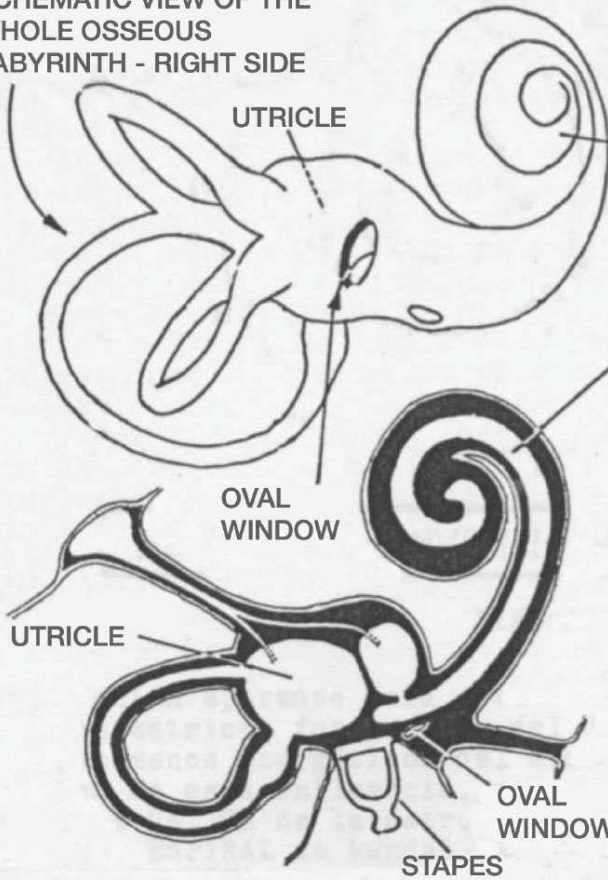

A FRONTAL SECTION OF THE AUDITORY SYSTEM (RIGHT EAR)

B SCHEMA OF THE PRELYMPHATIC AND ENDOLYMPHATIC SPACES

